

2026

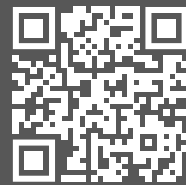

***Hoister***



***Kolster***

## About us

Kolster is a renowned Polish manufacturer with almost 80 years of experience specializing in mechanical and electromechanical equipment for rail traffic systems and signalling. Situated in Olsztyn, the capital of the Warmia & Mazury region in northeastern Poland, our company has a rich history dating back to 1885 when our manufacturing facility was established to produce iron products and machinery.

Over the years, Kolster has evolved significantly. In 1945, we became a part of the PKP Group and later transitioned into an independent state company. Following privatization in 2012, Kolster was acquired by the Stalmot Group S.A., a prominent Polish company with seven metal-working manufacturing plants and employing over 1500 people across various departments.

Our production site in Olsztyn is well-equipped with modern machinery and facilities, allowing us to undertake a comprehensive range of steel processing activities including milling, drilling, turning, bending, plasma cutting, laser cutting, welding, shot blasting, surface treatment, assembly, riveting, torque tightening and wet painting.

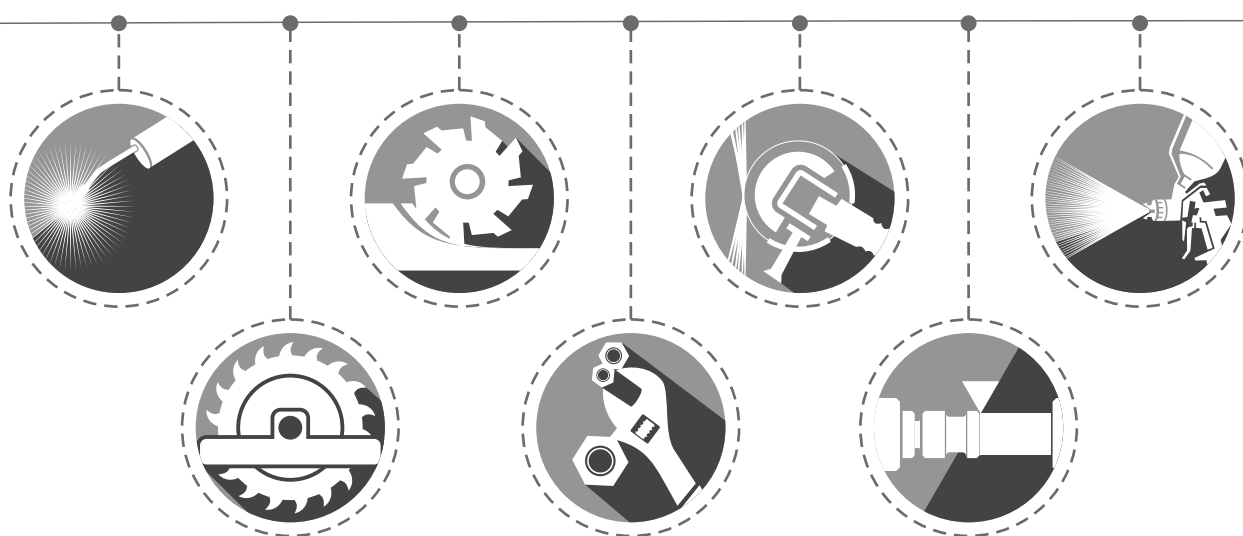

At Kolster, we prioritize safety and quality. Our quality management system adheres to ISO 9001:2008, EN1090, and EN15085 standards, overseen by experienced quality engineers and International Welding Engineers (IWE). This commitment to quality ensures that our products meet stringent industry standards.

Our clientele includes national and international suppliers of rail traffic systems and signaling, such as PKP (Polish State Railways) and Deutsche Bahn AG. We offer a diverse portfolio of over 1000 products, spare parts, engineering consulting services, as well as maintenance and construction services tailored to the rail industry's needs.

Our product development is guided by advanced production technologies, railway safety standards, and close collaboration with end-users to ensure our solutions are effective and efficient. With extensive expertise in signaling, rail traffic management, rail infrastructure, mechanical engineering, metalworking, and consulting services, Kolster remains a trusted partner in the rail industry, delivering innovative solutions and exceptional service to our valued customers.



1	SWITCH POINT LOCKS.....	5
1.1	UZZ-1-UNIVERSAL POINT LOCK .....	7
1.1.1	UZZ-100 .....	8
1.1.2	UZZ-100/M2.....	10
1.1.3	UZZ-100/V .....	12
1.1.4	UZZ-100/K .....	12
1.2	MANDREL POINT LOCK EEZ-1 .....	14
1.3	EMERGENCY RAIL CLAMP EEZ-7 .....	15
1.4	DERAILER LOCKS EEZ-5 .....	17
1.4.1	EEZ-5021 .....	17
1.4.2	EEZ-5022 .....	17
2	CABINETS .....	18
2.1	SKZ -Key cabinets .....	19
2.2	Switch point lock cabinet.....	22
3	DERAILER .....	24
3.1	GENERAL INFORMATION .....	25
3.2	CONSTRUCTION .....	26
3.3	VARIANTS .....	27
3.4	INSTALLATION .....	28
3.5	WKN SETTING.....	30
4	SIGNALS AND SIGNAL SWITCH STANS .....	32
4.1	DERAILER SIGNALS .....	34
4.2	SIGNAL SWITCH STAND .....	35
4.3	OTHER TYPES OF SIGNALS .....	36
4.4	DOUBLE CROSSING SIGNALS .....	37
4.5	SIGNAL SWITCH STAND .....	38
4.6	LIGHTENING UNIT ZOL-1 .....	41
5	BALISE MOUNTING SYSTEM MBK-1 .....	42
5.1	MBK PROTECTOR .....	46
6	BACKDRIVES .....	48
7	MOUNTING KITS FOR POINT MACHINE .....	51
8	CABLE ACCESSORIES .....	53
8.1	VF-10 AND JVF-10 JUNCTION POTS .....	54
8.2	JVA -10 TERMONAL BOX .....	56
8.3	MOUNTINGS FOR TERMINAL BOXES AND CABLE ACCESSORIES .....	59



1

SWITCH POINT LOCKS

---

# 1 SWITCH POINT LOCKS

## General information

Point locks are designed to close in specific positions of devices important for railroad traffic control (switches, derailleurs, setting devices) in order to achieve permanent mutual dependencies of these devices conditioning traffic safety or only temporary protection of these devices, e.g. in case of emergency. Point key locks are designed with specific features to ensure security and prevent unauthorized access.

- **Fixed Attachment:** Once a key lock is installed and locked onto a device, it cannot be easily disconnected or moved to another position without the appropriate key.
- **Key Dependency:** The removal of the key from the lock is only possible when the lock is in the closed (locked) position. This ensures that the key's presence is proof of the lock being engaged and securing the device.

Overall, key locks are designed with precision and complexity to provide effective security and prevent unauthorized tampering . The variety of key configurations and their interaction with the locking mechanism are crucial features of this security system.

The key lock mechanism may use a specific key to operate, providing a level of security and control over the point locking system.

- **Key Variability:** To enhance security and prevent unauthorized key duplication, key locks are designed with a variety of shapes (registers) and cutouts (groups)- 24 shapes and 6 types of cutouts, resulting in 144 unique key varieties.
- **Shapes (Registers)** refer to the physical configuration of the key's working part, such as the pattern of grooves or notches along its blade.
- **Cutouts (Groups)** are the specific features or cuts on the key that interact with the locking mechanism inside the lock. The combination of different shapes and cutouts creates a large number of unique keys.
- **Security and Authentication:** The combination of the above features ensures that each key is specific to its corresponding lock. Removing and using the key provides proof that the lock is engaged and authorized to the device it secures.







KEY CUTOUT	GROUP	FORMS OF KEYS																							
		a	b	c	d	e	f	g	h	i	k	l	m	n	o	p	q	r	s	t	u	v	w	x	z
	0	a0	b0	c0	d0	e0	f0	g0	h0	i0	k0	l0	m0	n0	o0	p0	q0	r0	s0	t0	u0	v0	w0	x0	z0
	1	a1	b1	c1	d1	e1	f1	g1	h1	i1	k1	l1	m1	n1	o1	p1	q1	r1	s1	t1	u1	v1	w1	x1	z1
	2	a2	b2	c2	d2	e2	f2	g2	h2	i2	k2	l2	m2	n2	o2	p2	q2	r2	s2	t2	u2	v2	w2	x2	z2
	3	a3	b3	c3	d3	e3	f3	g3	h3	i3	k3	l3	m3	n3	o3	p3	q3	r3	s3	t3	u3	v3	w3	x3	z3
	4	a4	b4	c4	d4	e4	f4	g4	h4	i4	k4	l4	m4	n4	o4	p4	q4	r4	s4	t4	u4	v4	w4	x4	z4
	5	a5	b5	c5	d5	e5	f5	g5	h5	i5	k5	l5	m5	n5	o5	p5	q5	r5	s5	t5	u5	v5	w5	x5	z5

Table 1 Key register table

# 1.1 UZZ-1

The UZZ-1 universal point lock is deployed in situations where:

- There is a need to manually override or secure railway points in their extreme positions during emergencies.
- The standard point mechanisms fail to operate correctly, requiring manual intervention to ensure safe railway operations.

Compatibility:

The UZZ-1 universal point lock is a mechanical device designed for emergency closing of a set of points in its extreme positions, with an operational mechanism, or for closing a point blade adjacent and away from the stock rail in the event of the point's mechanism being non-operational. It replaces the bolt point lock and securing bolt point blade lock, previously used for this purpose. The lock is suited for closing any type of points with a point blade pitch of 140 - 160 mm on S 42, S 49 and S 60 rails.

The UZZ-1 locks come in two varieties, each serving specific purposes and offering different functionalities:

UZZ-100 (Universal Point Lock with Key Lock):

- The UZZ-100 is a universal point lock equipped with a key lock mechanism.
- This lock variant includes the ability to secure the switch using a key, enhancing security and control over the locking operation.
- The key lock feature allows authorized personnel to engage or disengage the lock as needed, providing an additional layer of security and preventing unauthorized access to the switch.

UZZ-101 (Universal Point Lock without Key Lock):

- The UZZ-101 is a universal point lock that does not include a key lock mechanism.
- This variant is designed for situations where key-based security is not required or where simplicity and immediate access are prioritized.
- The UZZ-101 lock is operated manually without the need for a key, making it straightforward to use in emergency situations or scenarios where quick action is essential.

# 1.1.1

## UZZ-100 UNIVERSAL POINT LOCK



Fig. 1 universal point lock UZZ-100

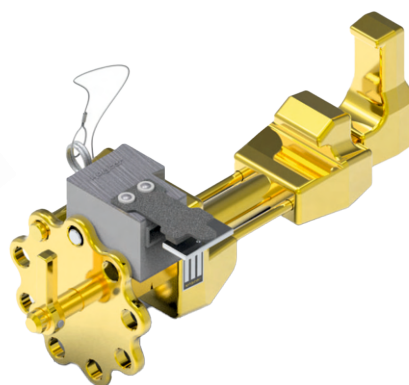

Fig. 2 UZZ-100/DE

The UZZ-100 universal point lock is a mechanical device used for emergency situations, serves a critical role in railway safety by enabling emergency closure of railway points (switch blades) when needed. This is particularly important for ensuring safe operation of trains by controlling the alignment of tracks.

### Components of the Universal Point Lock:

#### UZZ-101 Universal Point Lock (without Key Lock):

This component likely includes the mechanical apparatus responsible for physically locking the railway points in specific positions. It ensures that the points remain securely aligned under normal operating conditions.

The design of this lock enables it to be compatible with various types of railway points (with specific pitch measurements) and rail sizes (S 42, S 49, S 60 rails).

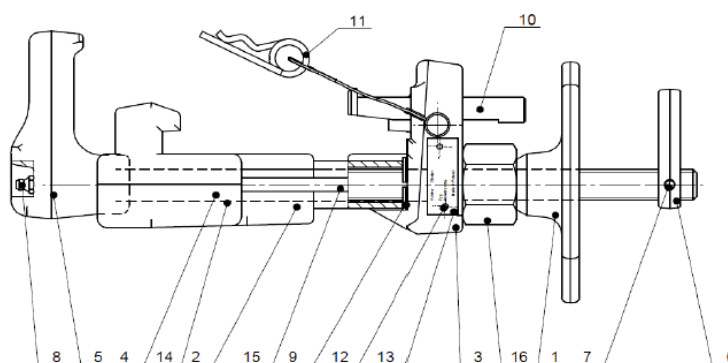

Fig. 3 UZZ-101

**Key Lock UZZ-102 :**

The key lock is a separate part of the UZZ-100 system and plays a crucial role in the security and control of the point lock.

It likely functions to enable or disable the operation of the universal point lock, ensuring that only authorized personnel can engage or disengage the lock.

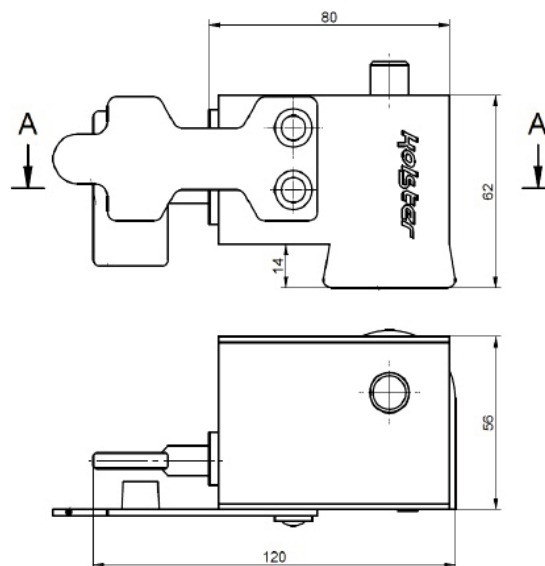

Fig. 4 UZZ-102 Key lock

**Purpose and Functionality:**

The Universal point lock UZZ-100 serves as a crucial component of railway safety systems designed to provide a reliable and immediate method for manually closing railway switches during emergencies. It ensures that the switch blade is securely positioned either in a retracted or pushed-towards state, directly onto the stock rail.

**Emergency Manual Closing:**

The primary function of the UZZ-100 switch lock is to facilitate emergency closure of railway switches when necessary, particularly in extreme positions.

**Versatility and Compatibility:**

The UZZ-100 switch lock is highly versatile and compatible with the following sizes of rails: S42, 49E1 (S49), 60E1 (UIC60). This flexibility eliminates the need for multiple lock varieties, streamlining operational procedures.

**Combination of Functions:**

The UZZ-100 switch lock integrates the functions of a MANDREL POINT LOCK and a Rail clamp EEZ-7. This combined functionality enhances the efficiency and effectiveness of the lock.

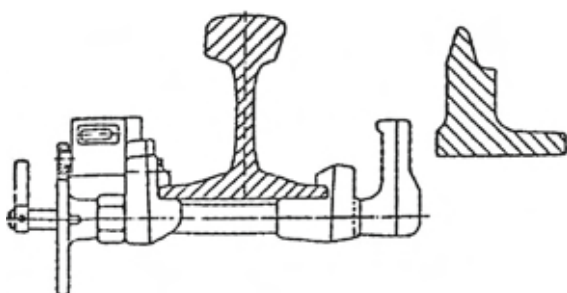

Fig.5 UZZ-100 in pushed-towards position

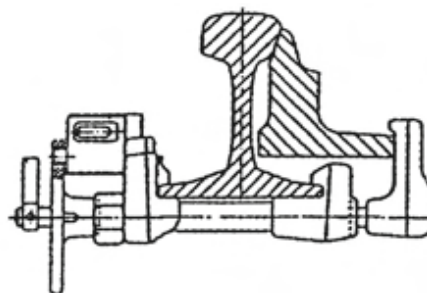

Fig. 6 UZZ-100 in retracted position

## Installation at Crossover:

Once installed, the UZZ-100 switch lock remains permanently positioned at the turnout. This strategic placement ensures that the lock is always ready for immediate use during emergencies, minimizing response times and enhancing operational readiness.

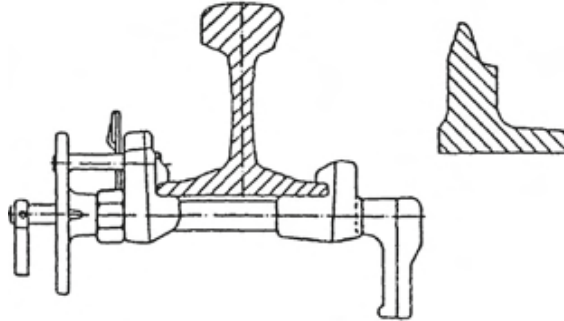

Fig. 7 UZZ-1 in neutral position

## Other Variants of point lock UZZ-1

### 1.1.2

#### UZZ-100/M2

The UZZ-100/M2 lock is a version of the UZZ-100 lock with expanded functionality intended to lock the point blade at the second point lock both in the adjacent and away position in relation to the stock rail.

#### Application:

Switch Blade Positioning: The lock is intended to secure the switch blade in both the "pushed-towards" position (towards the stock rail) and the retracted position (away from the stock rail).

#### Construction:

The UZZ-100/M2 universal lock has a unique expanded point blade lock. This lock contains a bumper with a part used to lock the point blade in the away position and with a part used to lock the point blade in the adjacent position.

#### Function:

The UZZ-100/M2 functions similarly to the UZZ-100 lock but is adapted for the second point lock, while the UZZ-100 lock is used to secure the first locking point.

## Operation:

Locking Mechanism:

Position 3 on Fig.8 : Locks the switch blade when pushed towards the stock rail.

Position 4 on Fig.8 : Locks the switch blade when retracted from the stock rail.

Adjustability: The lock can be rotated 180° to switch between locking positions (pos. 3 and pos. 4).

Switching to Neutral: Rotating the lock by 90° from any working position returns it to a neutral state where the lock bumper is horizontally positioned, presumably disengaging the lock from the switch blade.

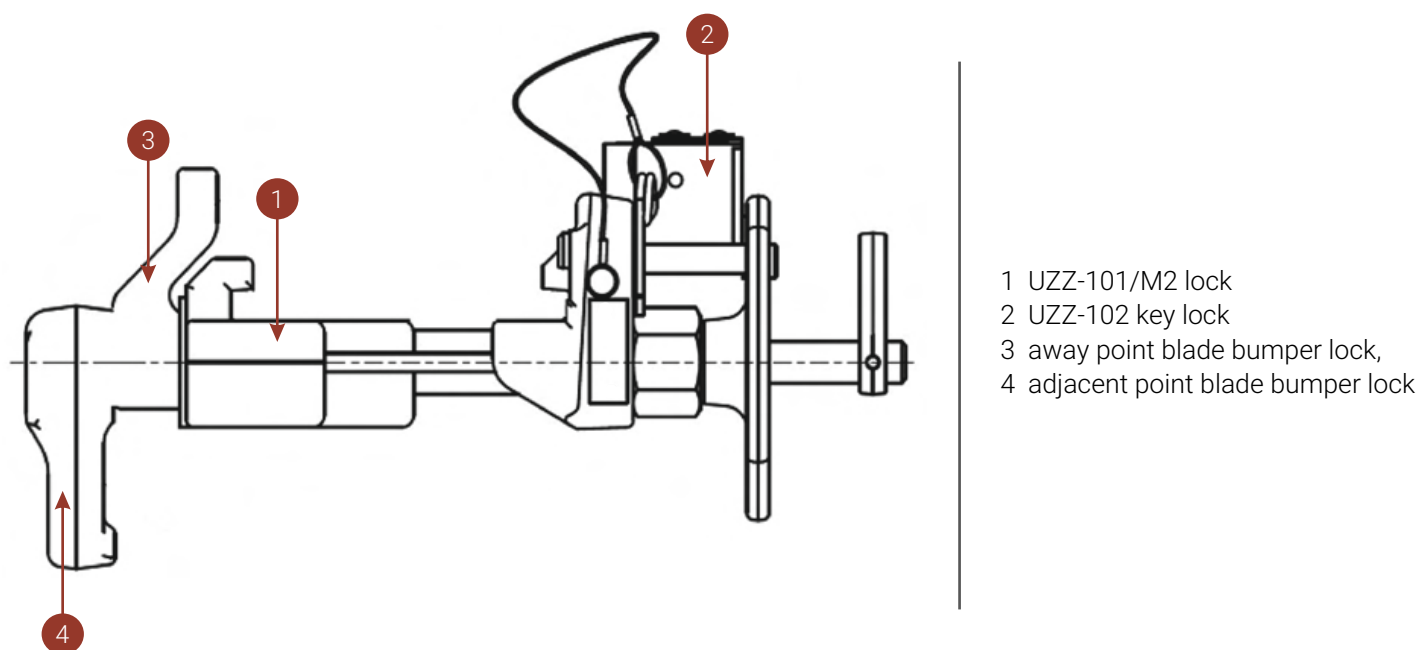

Fig. 8 UZZ-100/M2

# 1.1.3

## UZZ-100/V

### Function:

The UZZ-100/V lock is used for the first set of points lock VAE-manufactured turnouts, the operation remains unchanged like UZZ-100 lock. An important modification in the design adaptation for VAE turnouts is a slight change in the shape of the lock bumper (item 1 in Fig9) compared to the UZZ-100.

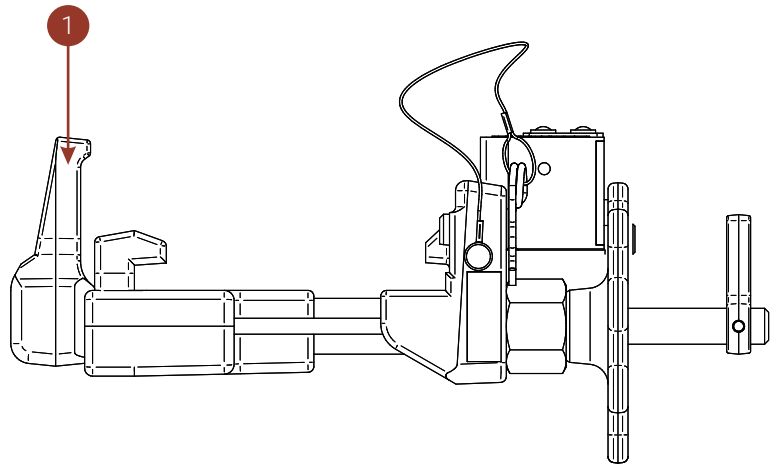

Fig.9 UZZ-100/V

# 1.1.4

## UZZ-100/K

### Function:

The UZZ-100/K lock differs from other UZZ-1 locks in its purpose: instead of closing the blades of a set of points, the UZZ-100/K lock is used for securing and closing swing noses of frog points.

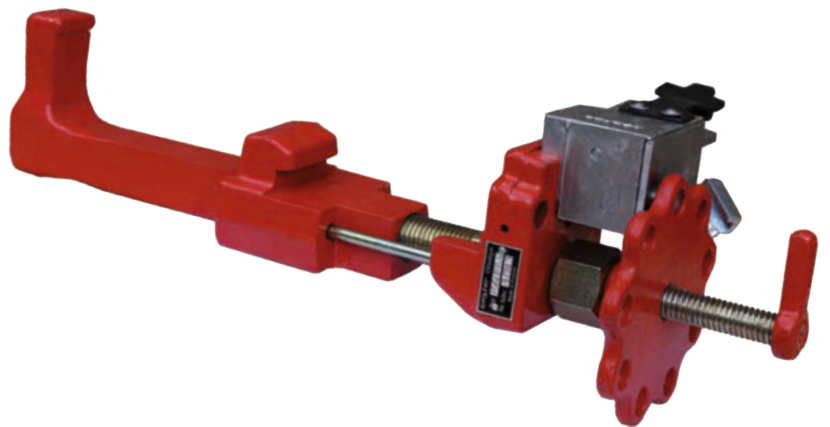

Fig. 10 UZZ-100/K

## Variants :

The variations in the UZZ-100/K lock (Table 1) address the specific requirements of different swing nose designs, ensuring compatibility and effectiveness.

Table 1 UZZ-100/K variants

Item no.	Description
UZZ-100/K1	Frog point swing nose R500 Koltram
UZZ-100/K2	Frog point swing nose R 1200 Huta Andrzej
UZZ-100/K3	Frog point swing nose R 1200 Koltram
UZZ-100/K4	For swing nose R500 Cogifer
UZZ-100/K6	Frog point swing nose R500 VAE
UZZ-100/K7a	I frog point swing nose lock R1200 VAE
UZZ-100/K7b	II frog point swing nose lock R1200 VAE
UZZ-100/K7c	I frog point swing nose lock R1200 VAE
UZZ-100/K9	II frog point swing nose lock R1200 KZN
UZZ-100/K10	Frog point swing nose R500 Cogifer
UZZ-100/K11	Frog point swing nose WBG/BWG HOLDING VAE R1200
UZZ-100/K12	Frog point swing nose TRACKTEC 60e1-500 HY-DRIVE

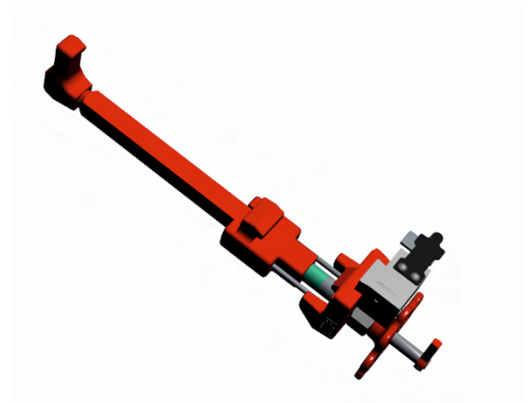

Fig. 11 UZZ-100/Kc

## Optional adjustments

For certain applications like the UZZ-100/K3, specific adapters are necessary to ensure proper positioning and operation of the lock within the turnout system. These adapters are designed to be installed on either the right or left side of the turnout, depending on the requirements of the installation.

The purpose of using these adapters is due to specific space or alignment requirements in the turnout system. By utilizing the appropriate adapter on the correct side of the turnout, the lock can function effectively and maintain the desired position as needed for proper railway operation. The selection is made after sending the specific dimensions of the turnout.

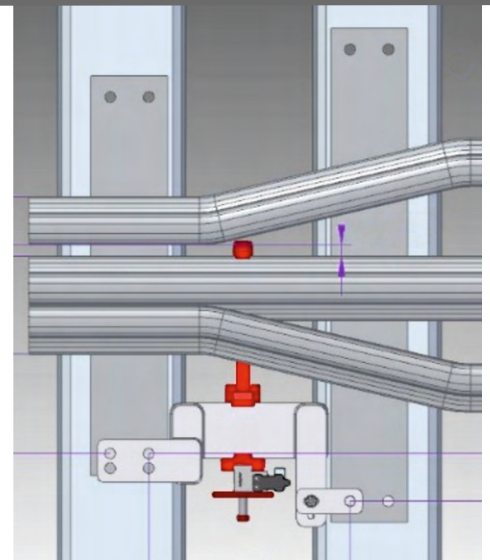

Fig. 12 UZZ-100/K7c  
with adapter

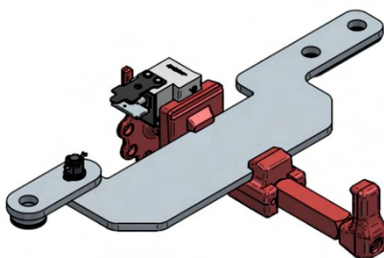

Fig.13 UZZ-100/K3 with 02-92040

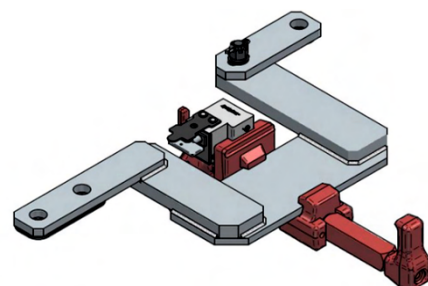

Fig. 14 UZZ-100/K3 with 03.02.00.00/L

# 1.2

## MANDREL POINT LOCK EEZ-1

The Mandrel Point Lock EEZ-1 plays a crucial role in railway safety and operation, allowing for emergency closure or controlled positioning of switch blades. Its installation involves securing the lock directly onto the stock rail, ensuring proper alignment and compatibility with the specific rail type. Understanding the lock's functionality and adhering to installation guidelines are essential for maintaining the integrity and safety of railway turnouts.

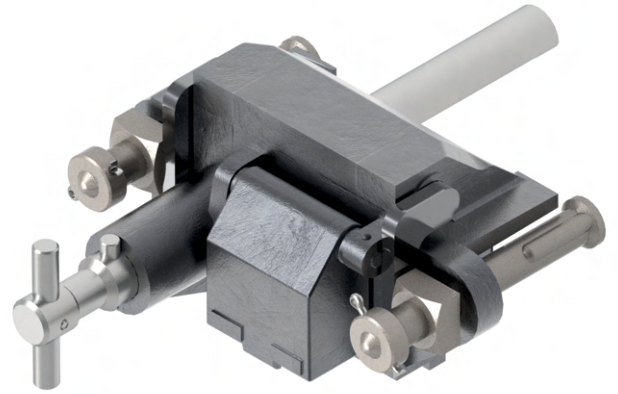

Fig. 15 Mandrel point lock EEZ-1

### Purpose and Functionality:

#### Emergency Closure:

Used to close switch blades in the retracted position only, primarily for emergency situations or to coordinate with other devices.

#### Installation:

Directly mounted onto the stock rail to secure the switch blade in place.

#### Locking Mechanism:

Once set and locked, the Mandrel Point Lock EEZ-1 cannot be removed or repositioned without the key.

#### Key Management:

Removing the key from the lock determines the specific position of the switch blade – key removal indicates the closure of the turnout.

#### Control Requirement:

For full control over the turnout, mandrel point locks must be installed on both sides of the switch.

## Varieties of Mandrel Point Locks:

Table 2 Types of Mandrel point lock EEZ-1

Item no.	Description
EEZ-1042	Mandrel point lock designed for S42 type rails.
EEZ-1049	Mandrel point lock intended for type 49E1 (S49) rails
EEZ-1060	Mandrel point lock intended for type 60E1 (UIC60) rails

Differences in Lock Variants:

**Pin Length:** Varies depending on rail type to ensure compatibility and effective operation.

**Housing Design:** The shape of the lock's housing is tailored to work seamlessly with different stock rail configurations.

# 1.3

## RAIL CLAMP EEZ-7

The Rail clamp EEZ-7 is a specific type of locking mechanism used to secure switch blades in railroad turnouts. This device is designed for emergency or temporary securing of switch blades by locking them either in a retracted or pushed-towards position. The design and operation of this restraining device are unique, requiring specific key forms and groups for operation.

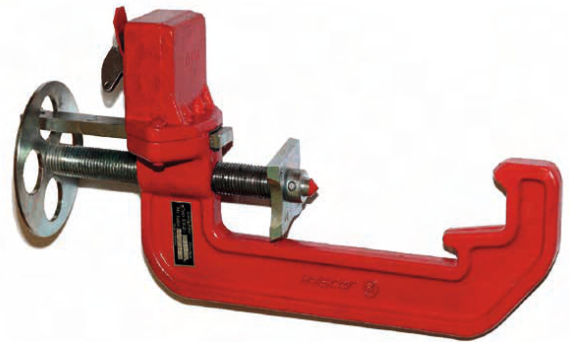

Fig. 16 Rail clamp EEZ-711

### Rail clamp (EEZ-711):

The only one variation of rail clamp that is offered is the restraining device of switch blade marked EEZ-711, which can be used with 49E1 (S49) and 60E1 (UIC60) turnouts. This suggests versatility in application across different switch types.

#### Purpose and Installation:

The rail clamp EEZ-711 is not intended for permanent installation on the switch blade.

It is applied temporarily during closures or emergency situations to secure the switch blade in a specific position.

Once the device is closed and locked, inserting the safety slide into the knob hole, closing the lock, and removing the key ensures temporary immobilization of the switch blade.

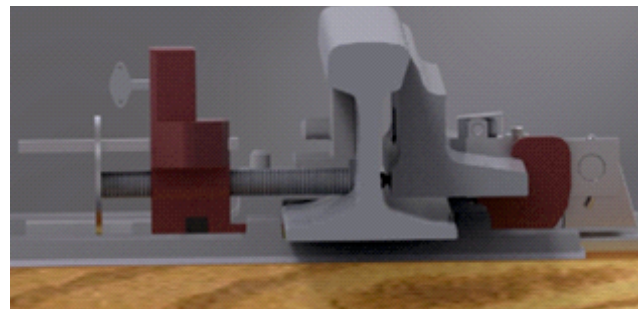

Fig. 17 EEZ-7 closes the switch blade in retracted position

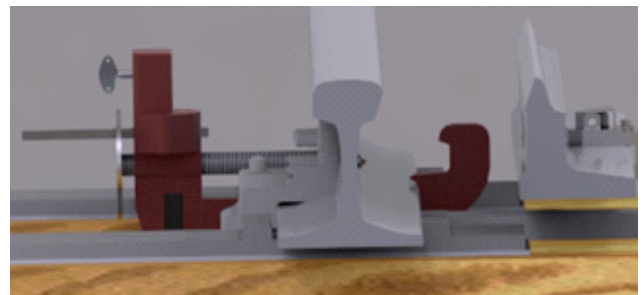

Fig. 18 EEZ-7 closes the switch blade in pushed toward position

**Temporary Locking Process:**

The rail clamp EEZ-711 serves safety measure during railroad operations, allowing for quick and effective temporary locking of switch blades when needed.

**Key Management:**

Once locked, the device cannot be removed without the corresponding key, ensuring secure and reliable operation during closures or emergencies.

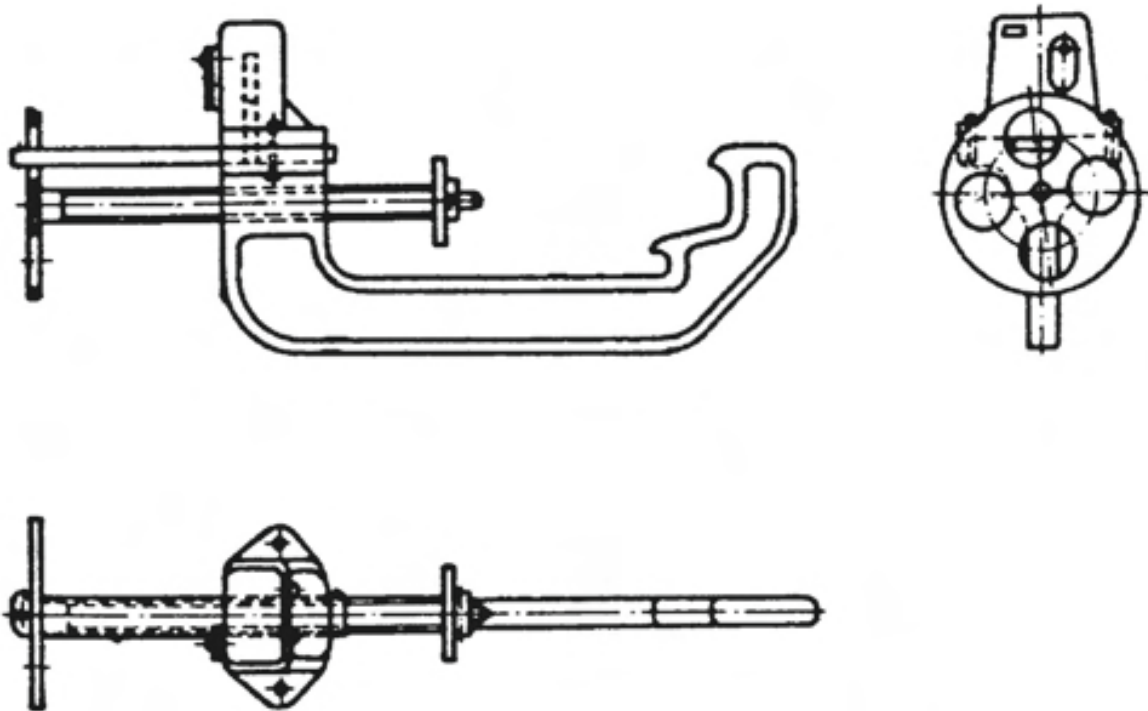

Fig. 19 Rail clamp EEZ-711

**Key Design and Variations**

The rail clamp EEZ-711 uses specific key forms and groups that differ from standard key locks. The shape and sizes of the keys and plates are unique to this lock mechanism.

Table 3 illustrates the range of available key forms and groups.

Table 3 EEZ-711 Key register

KEY CUTOUT	GROUP	FORMS OF KEYS										
		a	b	c	d	e	f	g	h	i	k	l
0	a0	b0	c0	d0	e0	f0	g0	h0	i0	k0	l0	m0
1	a1	b1	c1	d1	e1	f1	g1	h1	i1	k1	l1	m1

# 1.4

## DERAILER LOCKS EEZ-5

Derailer locks are used to close the derailer in a certain position, in the derailing position on the track, in the effective position or in both positions.

There are two variations of the EEZ-5 lock:

- EEZ-5012 : closing of the derailer lock in the derailing position on the track (closed track)
- EEZ-5022: closing of the derailer lock in the effective position (open track).

The basic design of the lock is the same in both cases, the differences are in the fastening elements and are due to the place of installation.

The derailer locks play a crucial role in maintaining track safety and ensuring proper derailer positioning during railway operations

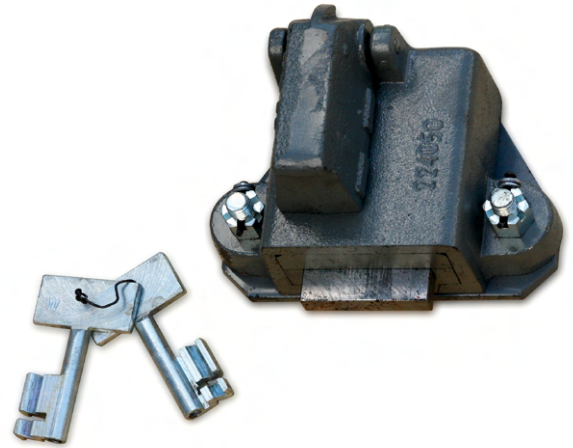

Fig. 20 EEZ-5

### 1.4.1

#### EEZ-5012 LOCK

- is used to close the derailer in the derailing position (on a closed track).
- is attached directly to the derailer beam using two square-headed bolts with crown nuts.
- the fastening elements used here are designed for secure attachment to the derailer beam.
- after installation, the nuts securing the lock should be further secured with rivets to prevent loosening.

### 1.4.2

#### EEZ-5022 LOCK

- is used to close the derailer in the effective position (on an open track).
- is fixed to the derailer foundation plate using a riveted mounting plate designed for this purpose.
- the mounting plate, along with countersunk fastening screws and crown nuts, is integrated into the lock assembly.
- unlike the EEZ-5012 lock, the EEZ-5022 lock requires additional accessories for mounting to the derailer.
- after installation, similar to the EEZ-5012 lock, the nuts securing the lock should be riveted to ensure they remain in place.

# 2

## CABINETS

---

# 2.1 SKZ -KEY CABINETS

Point lock cabinets are designed for storing active, spare and reserve keys for point locks, temporarily or permanently installed or to locks with keys and cranks of point machines. They give the opportunity to protect keys and locks and place them in a specific place in a clear and organized manner.



Fig. 1 SKZ Key cabinet

## Purpose-built Design:

The cabinets are tailored for the exclusive storage of active, spare, and reserve keys related to point locks and cranks of point machines. They aim to maintain organization and security for these critical components.

## Inner and Outer Wall Structure:

The cabinet likely features an inner wall for storing reserve and spare keys, keeping them separated and protected. The outer wall, which is openable, is designated for active and spare keys that require regular access.

## Locking Mechanism:

Each cabinet is equipped with a lock and key system to restrict unauthorized access to the stored keys. This ensures that only authorized personnel can retrieve the keys when needed.

## Security Features:

Inside the cabinet, there's a stop pin with a hole for running a wire to seal it. This additional security measure helps prevent unauthorized access or tampering with the keys stored inside.

## Space Optimization:

The double door system helps minimize the overall dimensions of the cabinet while providing ample storage space for different types of keys and locking components.

## Mounting Options

Standard versions of cabinets are designed for wall mounting, which enhances security and stability. They can also be available in a standing version (Fig.2) if requested. Table 1. Presents the variants of Cabinets.

Table 1 Key cabinets Variants

Variant	SKZ-10	SKZ-20	SKZ-40	SKZ-96
Key holder number	10	20	40	96
Dimensions (mm)	630x750x270	630x980x270	880x1100x270	770x1800x270

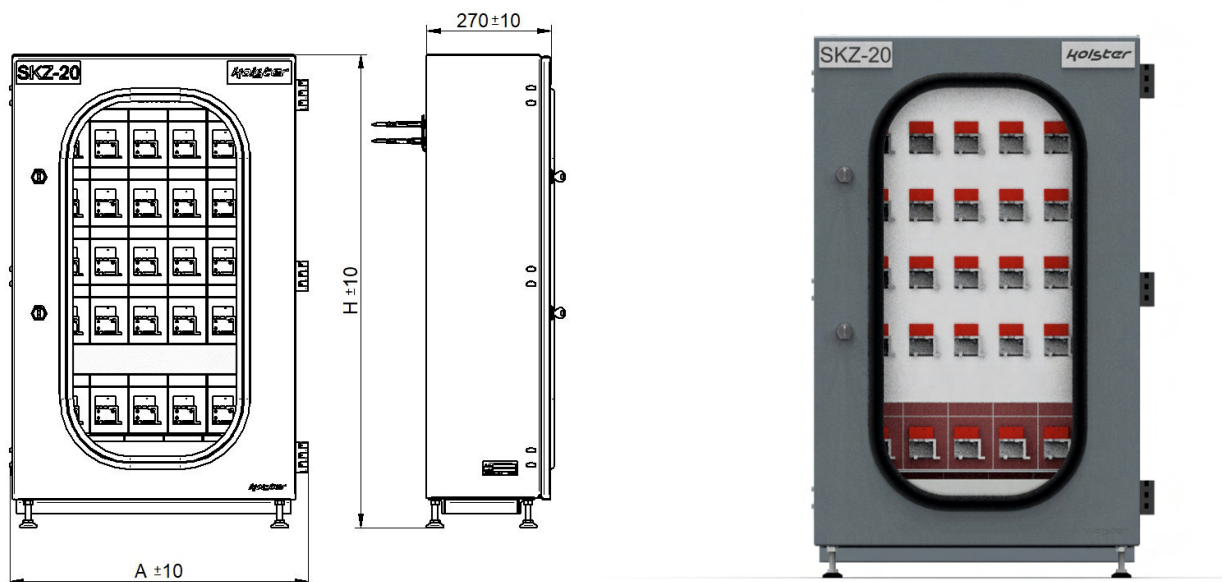

Fig. 2 SKZ-20 Key cabinet



Fig. 3 SKZ Cabinet standing version

On special request it is possible to customize the cabinets.

Due to the large number of possible combinations of equipment of cabinets when ordering, it is necessary to specify in detail the expected contents of the cabinets, e.g.

Cabinet for 10 key hangers, and 2 brackets for universal point locks UZZ-100 presented on Fig. 4.

SKZ cabinet equipment selection table is shown in Table 2.

Table 2 SKZ cabinet equipment selection table

SKZ cabinet equipment selection table						
Key cabinets variants	Type of cabinet	SKZ-				
	SKZ-10	10				
	SKZ-20	20				
	SKZ-40	40				
	SKZ-96	96				
Key hangers	Type of keys					
	Active	KC	X			
	Reserve	KR	X			
	Spare	KZ	X			
	Drive	KN	X			
	EEZ-5 Rail clamp	KS	X			
	Other	KI	X			
Bracket	Additional equipment					
	Drive crank			KO	X	
	UZZ-1 Point lock					ZU X
	Mendral point lock					ZT X
	EEZ-7 Rail clamp					S X

\* X stands for quantity

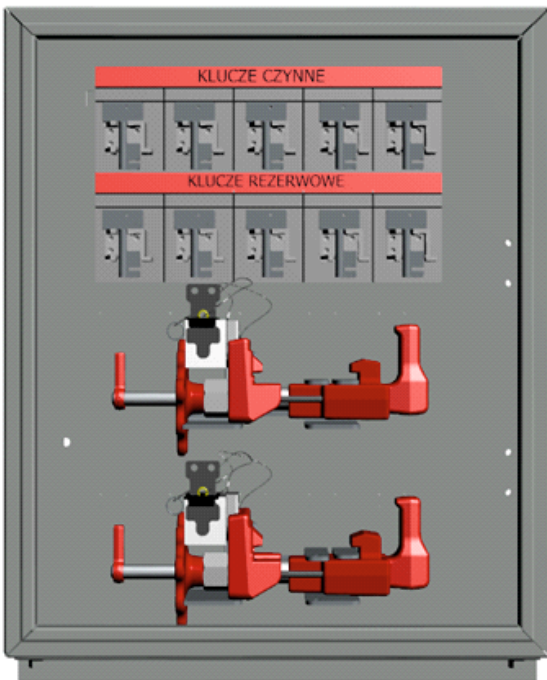

Table 3 Example of SKZ Key cabinets coding

SKZ cabinet equipment selection table						
Key cabinets variants	Type of cabinet	SKZ-				
	SKZ-10	10				
Key hangers	Type of keys					
	Active	KC	10			
	Reserve	KR	5			
	Spare	KZ	5			
Bracket	Additional equipment					
	UZZ-1 Point lock					ZU 2

Fig. 4 Example of cabinet SKZ-10 with 2 brackets for UZZ-100 SKZ-10KC5KR5ZU2

# 2.2

## SWITCH POINT LOCK CABINET

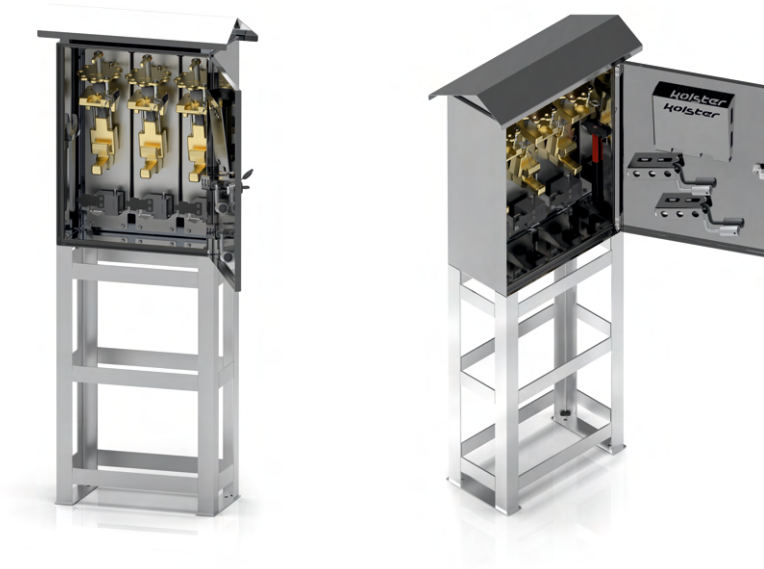

Fig. 5 Switch point lock cabinet

The switch point lock cabinets by Kolster offer a storage solution that's suitable for both indoor and outdoor use. They are built with construction to ensure the locks remain safe, from tampering or harm. Each cabinet type is equipped with a key lock.

Table 4 Versions of Switch point locks cabinets

Item no	Description	Cabinet	Base	Rain roof	Lock cover	Height [mm]	Width [mm]	Depth [mm]	Weight [kg]
DE05-93049	Outdoor Switch point lock cabinet (anchoring in the ground)	X	X	X	X	1730	600	310	62
DE05-93053	Indoor Switch point lock cabinet (anchoring to the floor)	X	X		X	1630	500	250	57
DE05-93054	Indoor Switch point lock cabinet (attachment to the wall)	X			X	630	500	250	29



Fig. 6 DE05-93049



Fig. 7 DE05-93053



Fig. 8 DE05-93054



#### Specification of cabinet DE05-93049 :

- Color RAL 7031
- Concealed door with seal
- Rear panel removable from inside
- Dimensions without rain cover 630x500x250
- Base H=1000 [mm]
- Cabinet is used to store:
  - 3 manual locks HV 73
  - 3 locking devices
  - 1 key SW 39
  - 1 hammer 500g
- Additionally on the door:
  - A4 document compartment, 2 hand cranks
  - 2 sets of door keys as standard



3

DERAILER

---

# 3.1

## GENERAL INFORMATION

A derailer is a safety device used to prevent unauthorized or uncontrolled movements of rolling stock. It functions by physically diverting the wheels of a vehicle off the track, effectively stopping it from continuing on its path. This mechanism is particularly useful in preventing accidents and ensuring the safety of rail operations.

WKN type derailer can derail vehicles traveling at speeds up to 25 km/h. In the case of low speed of the rolling stock, below 10 km/h, a derailer can only cause it to stop.

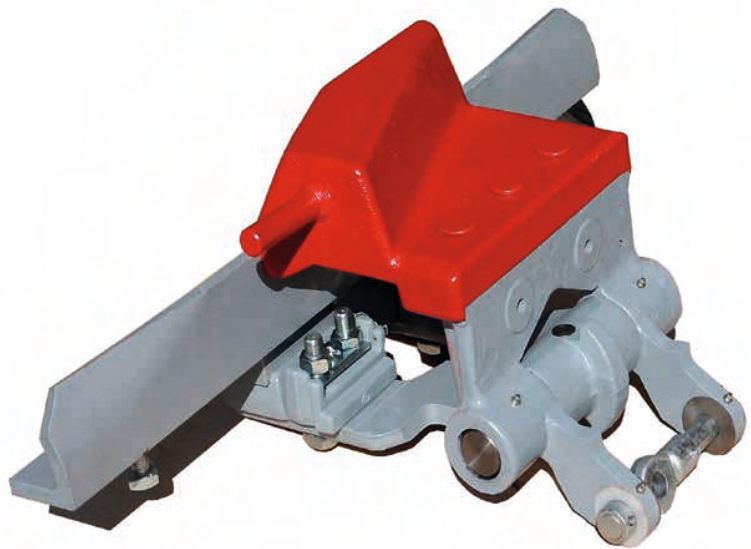

Fig. 1 WKN derailer

Proper selection of installation locations is crucial. The direction in which derailing is intended to occur should be chosen carefully to minimize safety risks and prevent damage to auxiliary trackside equipment.

When the derailer's wedge plate is disengaged, it allows the normal traffic of rolling stock to proceed at the maximum allowed shunting speed without obstruction.

# 3.2

## CONSTRUCTION

The major component of the derailer (Fig. 2) is the wedge plate 1 (2) shaped to throw vehicle wheels out of the rail 50 to the desired side of the track, so called derailing side, since that side has a low edge and a sloped cast riser. The edge at the opposite side is abrupt to prevent vehicle wheel to climb onto the wedge plate. The wedge plate is fixed by means of three rivets 31 to the support holder 3 whilst the holder is rotary connected to the base 6 with a socket formed therein. The socket enables installation of the derailer on a rail by means of such facilities as a yoke 7, a spacer 8 and a screw 20.

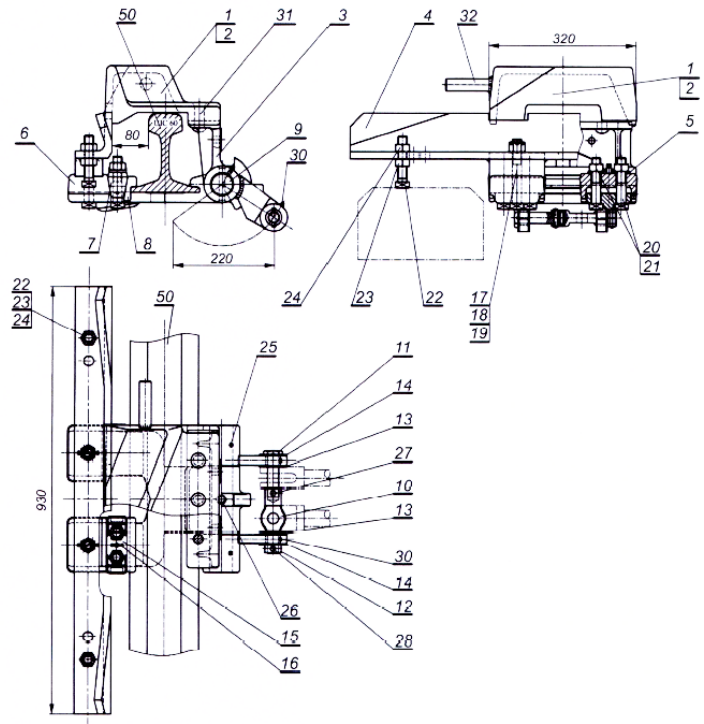

Fig. 2 Derailer of the WKN type – overall dimensions and major components

The control mechanism that is made up of a bracing joint 10 and a bolt 11 is insulated by means of a sleeves 13 and gaskets 14 is designed to attach the control bar of the derailer as well as coupling rod for the derailing signal lamp. In the rear part the derailer has a stopping angle bar 4 attached to the derailer by means of screws 17 designed to support the wedge plate when the derailer is in the derailing position. Auxiliary screws 22 are to be used as additional support for the angle bar when it rests on plates designed to fix rails to track sleepers.

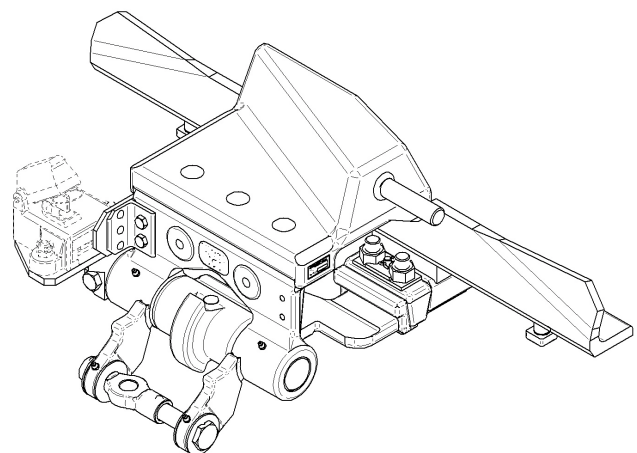

Fig. 3 WKN derailer

# 3.3

## VARIANTS

Derailers can be classified based on three primary factors: the type of rail they are attached to, the direction of rolling stock derailing (either to the right-hand or left-hand side when looking in the direction of travel), and their color marking system according to specific railway standards.

A derailer attachable to the S49 rail and forcing the vehicle to derail to the right-hand side is designed with the WKN-49P code whilst the device derailing vehicles to the left-hand side is referred to WKN-49L.

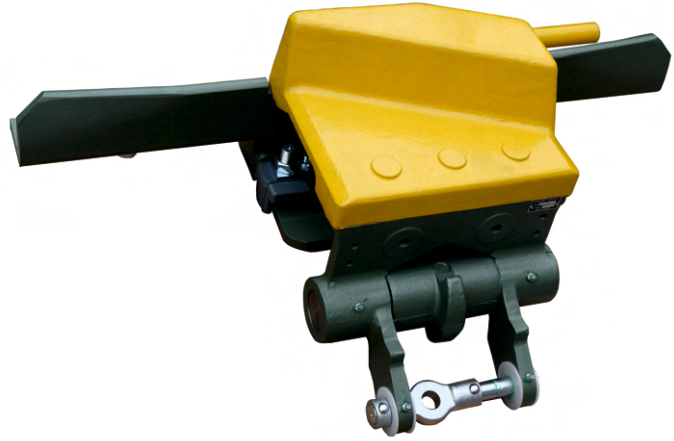

Fig.4 Derailer acc. to the DB standard

Similar marking system is also used for derailers designed for 60E1 (UIC60) and UIC54 rails, where respective design options are referred to as WKN-60P and WKN-60L.

The identification of derailers made according to DB standards begins with the prefix DE .

Table 1 Derailer variants

Item no.	Description
WKN-49L	Derailer S49 left without lock
WKN-49L/N	Derailer S49 left equipped with lock EEZ-5012 to secure the derailer in closed position
WKN-49L/NU	Derailer S49 left equipped with locks EEZ-5012 and EEZ-5022 to secure the derailer in open and closed position
WKN-49P	Derailer S49 right without lock
WKN-49P/N	Derailer S49 right equipped with lock EEZ-5012 to secure the derailer in closed position
WKN-49P/NU	Derailer S49 right equipped with locks EEZ-5012 and EEZ-5022 to secure the derailer in open and closed position
WKN-60L	Derailer UIC60 left without lock
WKN-60L/N	Derailer UIC60 left equipped with lock to secure the derailer in closed position
WKN-60L/NU	Derailer UIC60 left equipped with locks EEZ-5012 and EEZ-5022 to secure the derailer in open and closed position
WKN-60P	Derailer UIC60 right without lock
WKN-60P/N	Derailer UIC60 right equipped with lock to secure the derailer in closed position
WKN-60P/NU	Derailer UIC60 right equipped with locks EEZ-5012 and EEZ-5022 to secure the derailer in open and closed position
DE01331160	Wykolejnica 54R / Sw 80.0001 / gleissperre 54R / 49R ACC. to DB standard
DE01331177	Wykolejnica 54L / Sw 80.0002 / gleissperre 54L / 49L ACC. to DB standard
DE01331179	Wykolejnica 60L / Sw 80.0004 / gleissperre 60L ACC. to DB standard
DE01331188	Wykolejnica 60R / Sw 80.0003 / gleissperre 60R ACC. to DB standard

In individual cases, we offer derailers with an additional protective coating designed specifically for tropical conditions. By applying this specialized coating, we aim to provide reliable and long-lasting derailers that meet the unique demands of such climates.

# 3.4

## INSTALLATION

The place of installation of the derailer and the direction of derailment should be selected in accordance with the regulations established by the user of the railroad infrastructure. It is also important that the derailed rolling stock causes the least possible safety risk and minimizes the possibility of damage to trackside equipment.

Installation of the derailer is simple and fast. The dimensions of the derailer allow it to be installed between sleepers laid at a typical spacing of 650 mm (or even 600 mm), so there is no need to pull the sleepers apart.

### Installation Steps

#### 1 Remove Stopping Angle Bracket:

- Detach the stopping angle bracket (4) from the derailer device (refer to Fig. 2 and Fig. 4).

#### 2 Attach Derailer to Rail Foot:

- Align the derailer base socket (6) with the rail foot (50)
- Use clamping components: yoke and spacer (8).
- Secure with screws (20):
- Pass bolts through the base (6) holes.
- Place yokes (7) and securing plates (5).
- Tighten nuts (21).
- Insert spacers (8).

#### 3 Secure Clamping Components:

- After tightening nuts (21), fix them with securing washers (15) and cotter pins (16).

#### 4 Reinstall Stopping Angle Bracket:

- Reattach using bolts (17), castellated nuts (18), and cotter pins (19).
- Support with screws (22) secured with lock nuts (23) and (24).

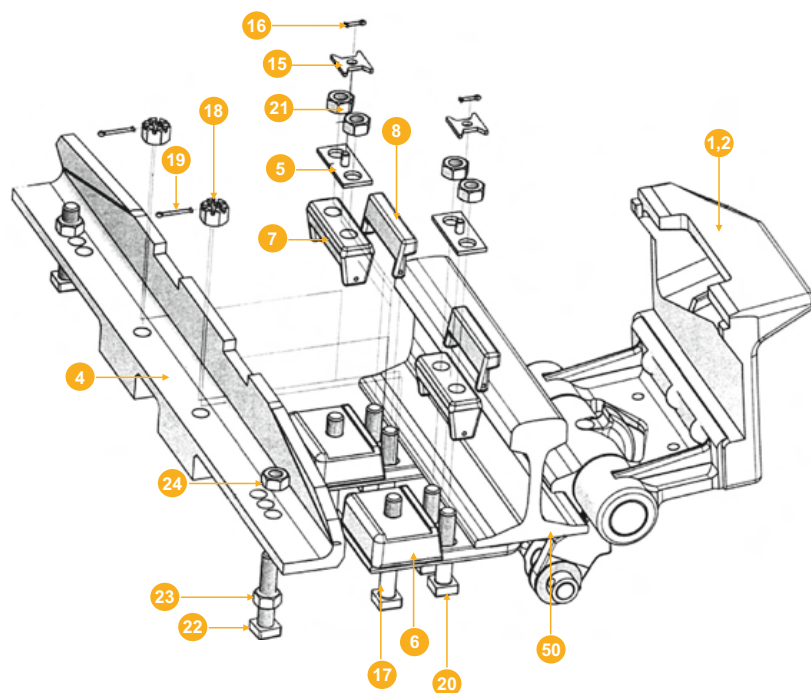

To verify the operation of the derailer, perform the following actions:

- Use the handle (32) of the wedge plate (12) to check if the derailer opens and closes smoothly.
- Ensure the rear edge of the wedge plate firmly rests on the stopping angle bracket (4).
- Ensure a gap of not less than 1 mm between the bottom plane of the wedge plate and the rail head (refer to Fig. 6).
- Confirm that the distance between the rail head and the wedge plate edge is 300 mm when the wedge plate is in the effective position (removed from the rail, refer to Fig. 5).

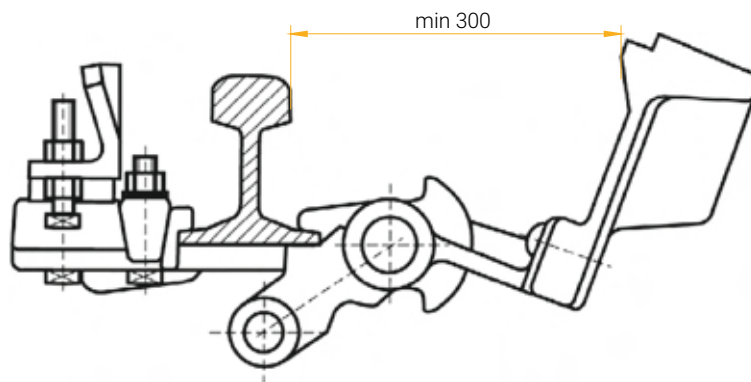

Fig. 5 Control dimension min. 300mm

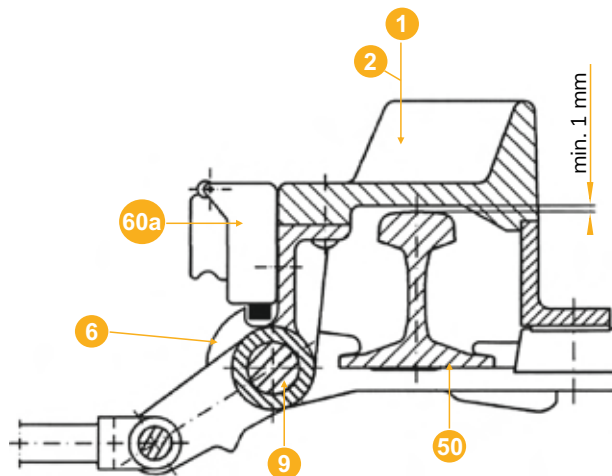

Fig. 6 Locking of the derailer in the derailing (left on) position

# 3.5

## WKN SETTING

WKN derailleurs can be set up, i.e. repositioned from the derailing position to the effective position can be carried out manually or by means of point machines. Manual repositioning is possible either directly, using the handle welded to the wedge plate, or indirectly using the switch stand/post with counterweight or mechanical point machine. The most common case is using the standard electric point machines. Due to the low switch force (below 1 kN), all point machines with an adjustment stroke of 220 mm can be used for this purpose.

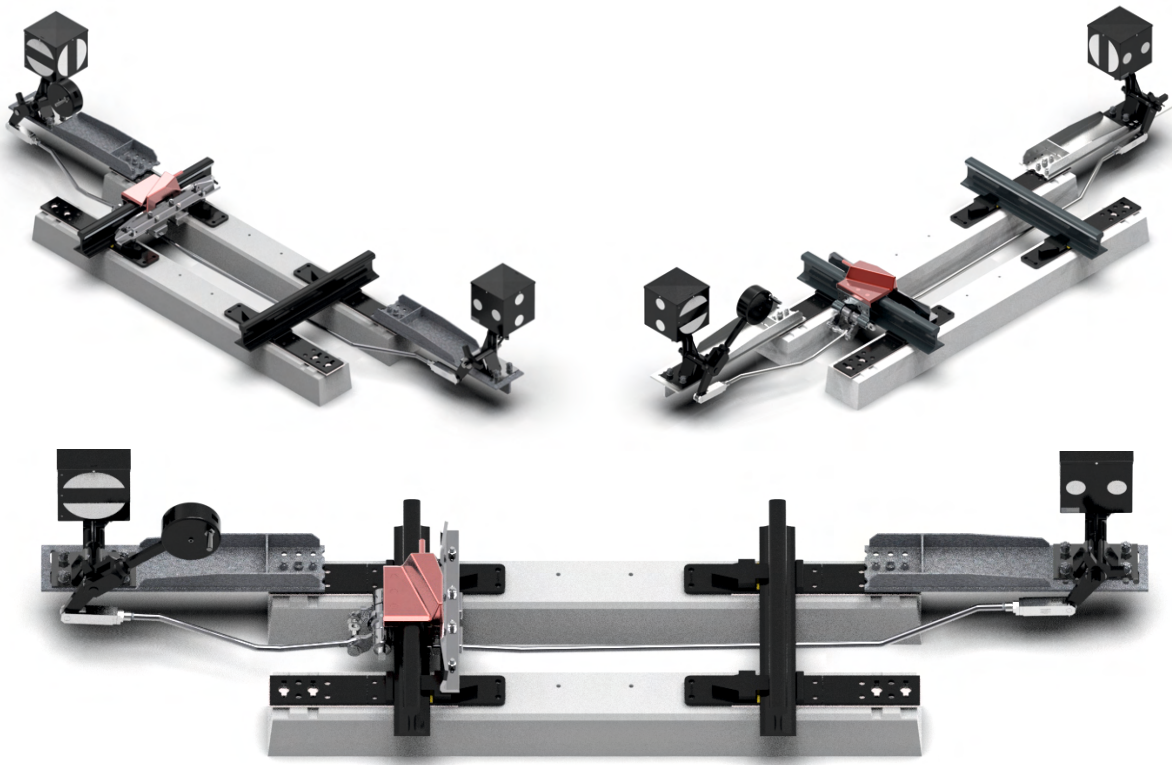

Fig. 7 WKN with lever and counterweight set

Table 2 Example of the set of manual reposition of WKN with lever and counterweight system

Item no.	Description
WKN-60L	Derailer for UIC 60 derailment direction left
ZWL-1	Signal switch stand
PW-1	Counterweight
03-92459	Rod connecting derailer WKN on the left side of the track with signal on the left side
03-92460	Rod connecting derailer WKN on the left side of the track with signal on the right side
03-93330/3	Bracket
LWK-220	Derailer signal with reflective symbols execution II (left)

Examples of connections between railroad switching drives and derailleurs are shown in Fig 8,9,10,11.

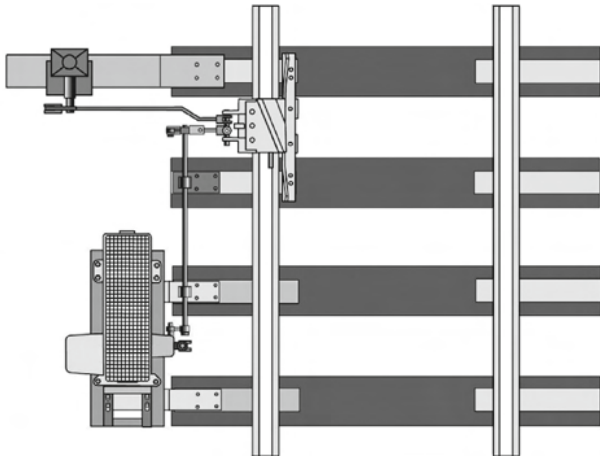

Fig. 8 WKN derailer with EEA-4 point machine

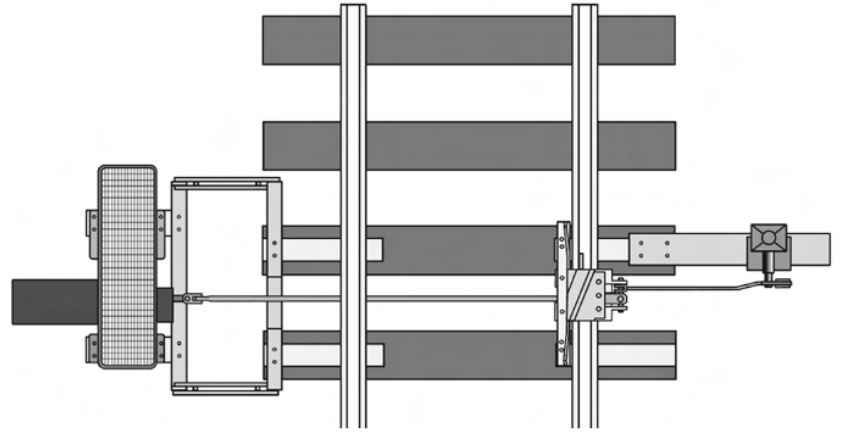

Fig. 9 WKN derailer with JEA-29 point machine

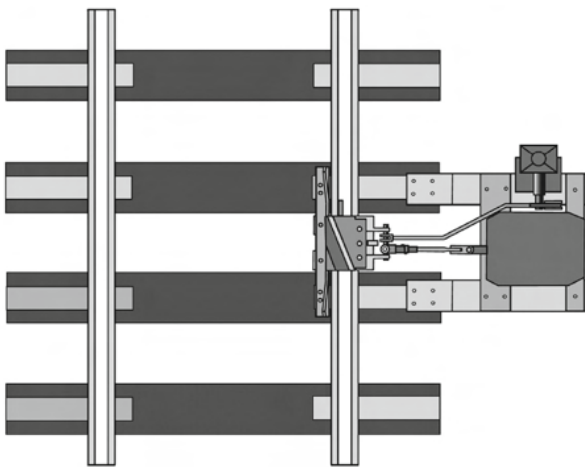

Fig. 10 WKN derailer with S7000K point machine

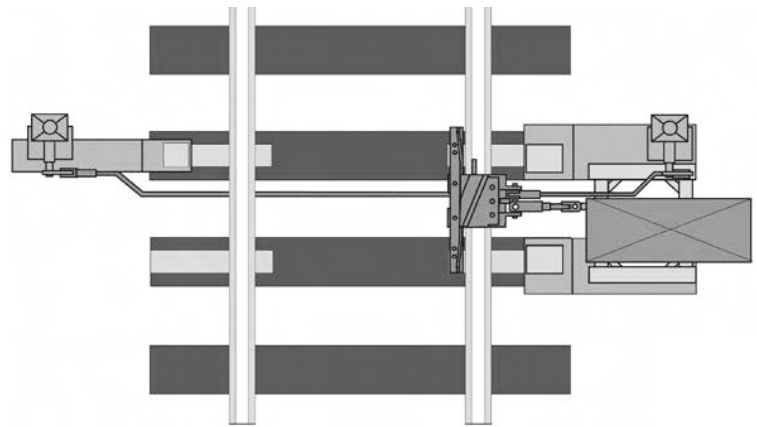

Fig. 11 WKN derailer with EEA-5 point machine



# 4

## SIGNALS AND SIGNAL SWITCH STANDS

---

# 4

## SIGNALS AND SIGNAL SWITCH STAND

Derailers and switch point signals providing clear indications about the status of derailleurs and switch points on railway tracks.

They are made in the form of a rectangular box colored black with symbols in white. Each wall of the box contains its characteristic symbols. In the basic version, the symbols are covered with a milky-white polycarbonate panel resistant to ultraviolet rays and mechanical damage. A lighting unit ZOL-1 is used to illuminate the symbols on the signal, ensuring they are visible in various lighting conditions.

An alternative design features reflective symbols, ensuring visibility without internal illumination.

Signals are placed on signal switch stand, which put them in the correct position for the state of the derailment or switch. The switch stand move the indicators to the correct position according to the state of the switch or derailer by rotating the indicator . The indicator for double-crossing turnouts is stationary , and the signal is changed by rotating the signal covers.

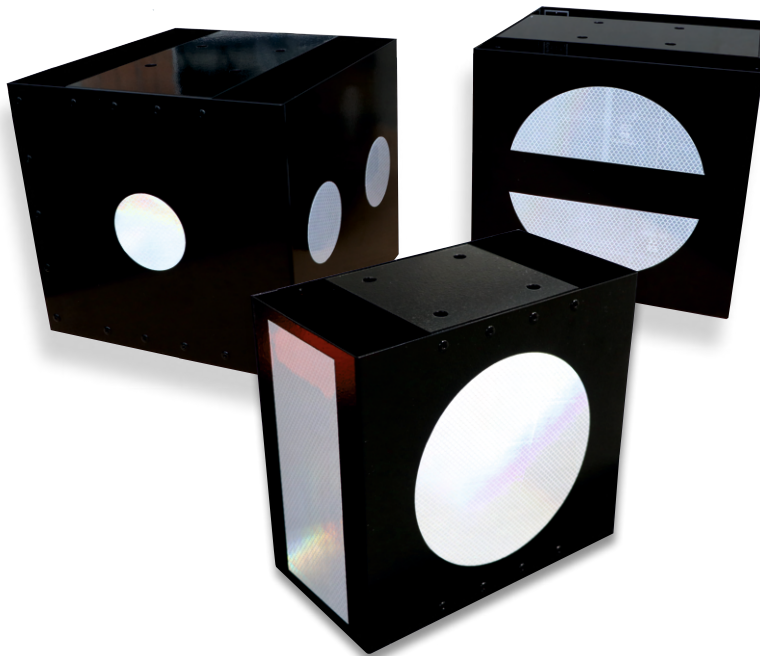

Fig. 1 Signals

# 4.1

## DERAILER SIGNALS

Table 1 Derailer signals acc. to PKP Standard

Item no.	Description
LWK-111	Derailer signal adapted for lightening unit execution I (right)
LWK-121	Derailer signal adapted for lightening unit execution II (left)
LWK-210	Derailer signal with reflective symbols execution I (right)
LWK-220	Derailer signal with reflective symbols execution II (left)



Fig. 2 LWK



Fig. 3 LWK adapted for lightening unit

Table 2 Derailer signals acc. to DB Standard

Item no.	Description
DE01329033	Gleissperrensignal Sh0/Wn7 rückstrahlend/Derailer signal Sh0/Wn7 reflective
DE01364270	Gleissperrensignal Sh0/Wn7 Form A bel./Derailer signal Sh0/Wn7 Form A with lighting
DE01364287	Gleissperrensignal Sh0/Wn7 Form B bel./ Derailer signal Sh0/Wn7 Form B with lighting

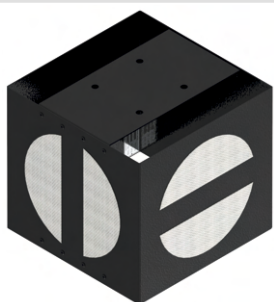

Fig. 4 DE01329033

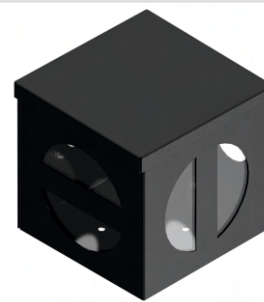

Fig. 5 DE01364270

For WKN derailers manufactured by Kolster Sp. z o.o., we offer additional elements working with signals, such as signal rods with length adjustment, base and signal switch stand.

The selection of lantern rods for WKN derailers is facilitated by the following application, please see below the Table 3.

Table 3 Selection of the rods for WKN

Item no.	Description
03-92457	Rod connecting derailer WKN on the right side of the track with signal on the right side
03-92458	Rod connecting derailer WKN on the right side of the track with signal on the left side
03-92459	Rod connecting derailer WKN on the left side of the track with signal on the left side
03-92460	Rod connecting derailer WKN on the left side of the track with signal on the right side

# 4.2

## SWITCH POINT SIGNALS



Fig. 6 LZW adapted for lightening unit

Table 4 Switch signals acc. to PKP Standard

Item no.	Description
LZW-111	Switch signal adapted for lightening unit execution I (right)
LZW-121	Switch signal adapted for lightening unit execution II (left)
LZW-131	Switch signal adapted for lightening unit execution III (curved turnout)
LWK-211	Switch signal with reflective symbols execution I (right)
LWK-221	Switch signal with reflective symbols execution II (left)
LWK-231	Switch signal with reflective symbols execution III (curved turnout)

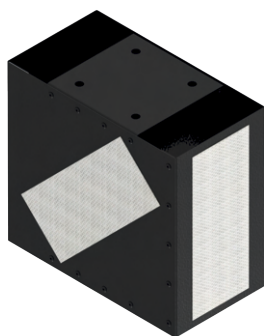

Fig. 7 DE01326813

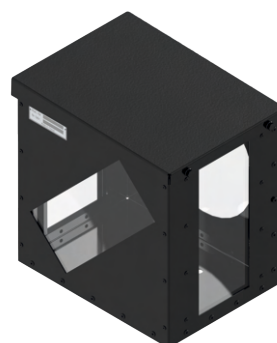

Fig. 8 DE01329052

Table 5 Switch signals acc. to DB Standard

Item no.	Description
DE01326813	Weichensignal Wn1/Wn2 rückstr. Form R/L/Switch signal Wn1/Wn2 reflective R/L
DE01369858	Weichensignal -R/L, Rückfallw. Orange / Switch signal R/L reflective orange
DE01329052	Weichensignal, Wn1/Wn2-R, beleuchtet/ Switch signal Wn1/Wn2-R with lighting
DE01329062	Weichensignal, Wn1/Wn2-L, beleuchtet/ Switch signal Wn1/Wn2-L with lighting
DE01329072	Weichensignal Wn1/Wn2 -Z, beleuchtet/ Switch signal Wn1/Wn2-Z with lighting

# 4.3

## OTHER TYPES OF SIGNALS

Depending on the project requirements, we implement various forms of switch lanterns according to customer specifications.

Item no.	Description
LZW-CR-111	Switch signal right with lighting -Croatia
LZW-CR-121	Switch signal left with lighting -Croatia
AZW-CR-210	Switch signal right reflective -Croatia
AZW-CR-220	Switch signal left reflective -Croatia
04-92032	Lighting unit
04-93111	Signal stand

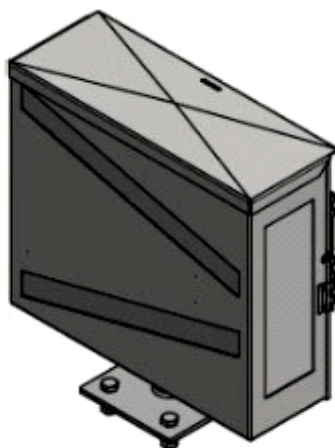

Fig. 9 LZW-CR-111

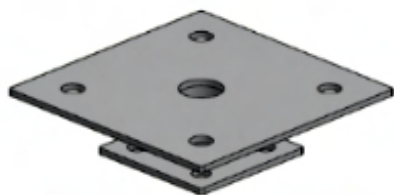

Fig. 10 04-93111

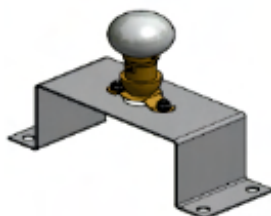

Fig. 11 04-92032

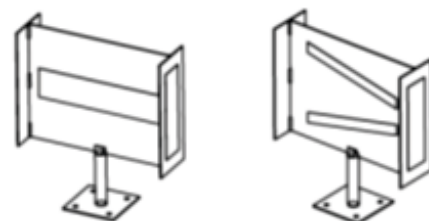

Fig. 12 AZW-CR-210

# 4.4

## DOUBLE CROSSING SIGNAL



Fig. 13 LCA-1

Double crossing signal version adapted for lighting unit with mounting base 026.011.0



Fig. 14 03-92599

Double crossing signal rod bracket

Table 6 Double cross turnout signals acc. to Polish Standard

Item no.	Description
LCA-1	Double crossing signal
03-92599	Double crossing signal rod bracket
03-92498	Double crossing signal rod
026.011.0	LCA -1 signal mounting base



Fig. 15 DE01326785

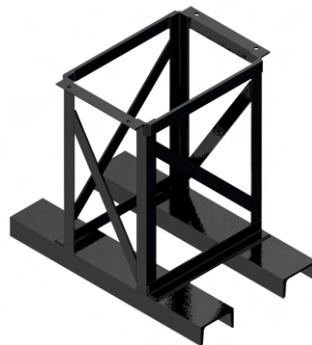

Fig. 16 DE06362011



Fig. 17 DE01326812

Table 7 Double crossing signals acc. to DB Standard

Item no.	Description
DE01326785	Weichensignal (DKW) Wn3-Wn6 rückstrahl. / Double crossing signal reflective
DE01326812	Weichensignal (DKW) Wn3-Wn6 beleuchtet/ Double crossing signal with lighting
DE06362011	Laternensockel / Signal mounting base

# 4.5

## SIGNAL SWITCH STAND

Signal switch stand is intended for mounting and controlling derailleurs and switch points signals. Ensures the signal displays the correct symbol to guide the rolling stock, enhancing safety and efficiency on the railway tracks.



Fig. 18 ZWL-1 Signal switch stand



Fig. 19 PW-1 Counterweight

### Function

The function of a signal switch stand is to set the signal with the relevant symbol in the direction of the rolling stock prohibiting entry or allowing entry of the rolling stock. Signal rods drive the switch stand, setting the appropriate signals to manage the entry of rolling stock effectively.

### Adaptability

Signal switch stand is adaptable for both point machine powering and manual control.

For manual control, the signal switch stand should be equipped with a counterweight produced by Kolster. The counterweight assists in the manual operation of the signal support.

Table 8 Signal switch stand and additional assesories

Item no.	Description
ZWL-1	Signal post
03-93037	Base for signal switch stand (used in case of installation of the post on the site of point machine ,using the point machine fixing kit )
PW-1	Counterweight
03-93330/3	LCA -1 signal mounting base

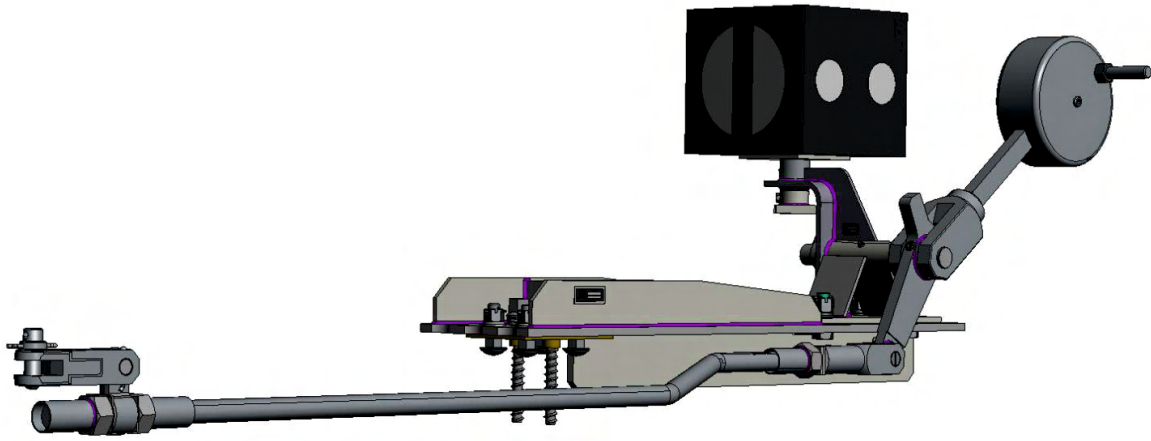

Fig. 20 Signal switch stand with installed signal, base, bracket and counterweight

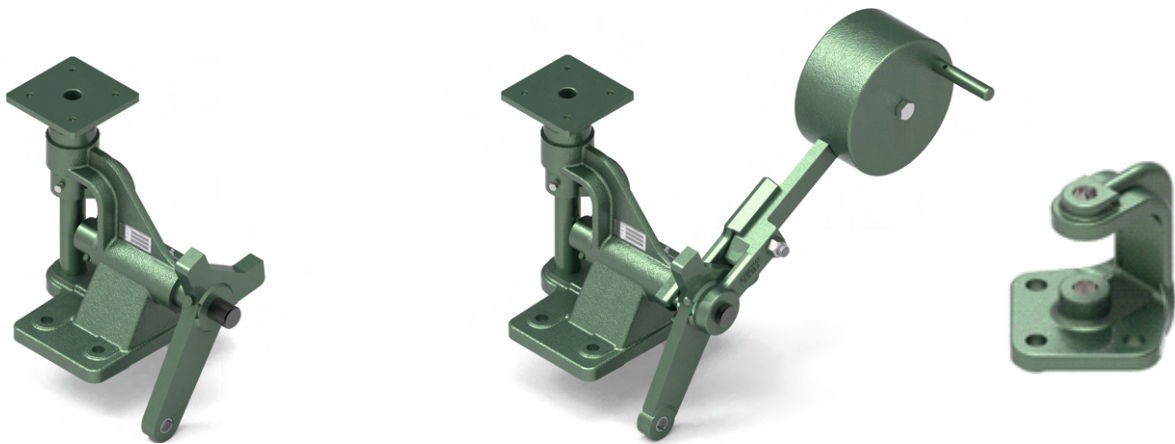

Fig. 21 DE01331788

Fig. 22 DE01331175

Fig. 23 DE01369864



Fig. 24 DE01327852

Fig. 25 DE01331147

Table 9 Signal switch stand acc. to the DB Standard

Item no.	Description
DE01369864	Lagerbock f. mechan. WA/ Mounting bracket f. mechan. WA
DE01327852	Bock für Weichensignal/ Signal switch stand
DE01331175	Stellbock mit Gewichtshebel 45 kg/ Operating stand with weight lever 45 kg
DE01331147	Stellbock mit Gewichtshebel 34 kg/ Operating stand with weight lever 34 kg
DE01331788	Lagerbock o Gewichtshebel/ Bearing block without weight lever

Table 10 Assesories acc. to the Db Standard

Item no.	Description
DE01369830	Gewichtshebel/ Weight lever
DE01369876	Gabelteil/ Fork part
DE05-93005	Gewichtshebel kpl./ Weight lever cpl.
DE01331822	Hubbegrenzung/ Stroke limiter
DE01346271	Hubbegrenzung/ Stroke limiter
DE01326811	Lagerung LE 330/Mounting LE 330
DE00559029	Leichter Erdfuß/ Light ground foot



Fig. 26 DE05-93005

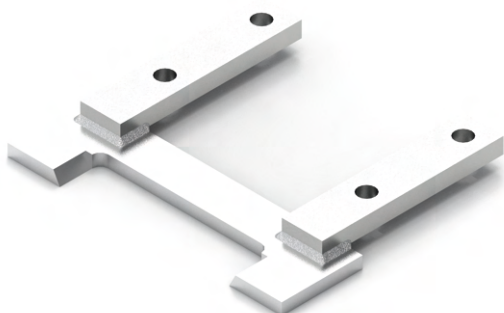

Fig. 27 DE01331822

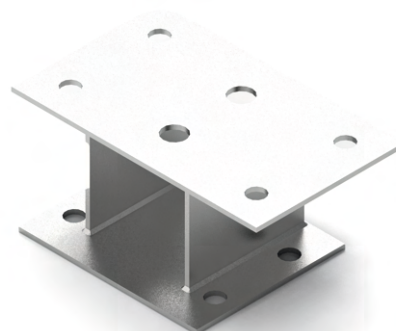

Fig. 28 DE01326811

# 4.6

## LIGHTENING UNIT ZOL-1

ZOL-1 lightening unit is used to illuminate switch and derailer signals adapted for lighting installation. It is made of a steel tube bent into the shape of the letter "U" (see Fig. 29). At its upper end is a B22d bulb holder attached to the adapter on a spring. The spring is designed to absorb vibrations from passing rolling stock, which significantly extends the life of the bulb. The signal lighting assembly is bolted to a JVA-10 cable box.

Table 7 Mounting set needed for ZOL-1

Item no.	Description
ZOL-1	Lightening unit
JVA -10	Cable box



Fig. 29 ZOL-1

JVA-10 cable boxes and brackets for these boxes are not included in the ZOL-1 and must be ordered additionally (see chapter 1. "Cable accessories").



# 5

BALISE MOUNTING SYSTEM MBK-1

---

# 5

## BALISE MOUNTING SYSTEM MBK-1



MBK balise mounting system by KOLSTER provides a practical solution for railway signaling applications, allowing for the efficient and reliable installation of balises onto various rail configurations. Its compatibility with different rail fastening systems and adaptability to different mounting positions make it a valuable asset for railway operators seeking to enhance safety and efficiency within their rail networks.

The MBK balise mounting system is specifically designed to facilitate the installation of balises onto railway tracks, providing a secure and adaptable mounting solution.

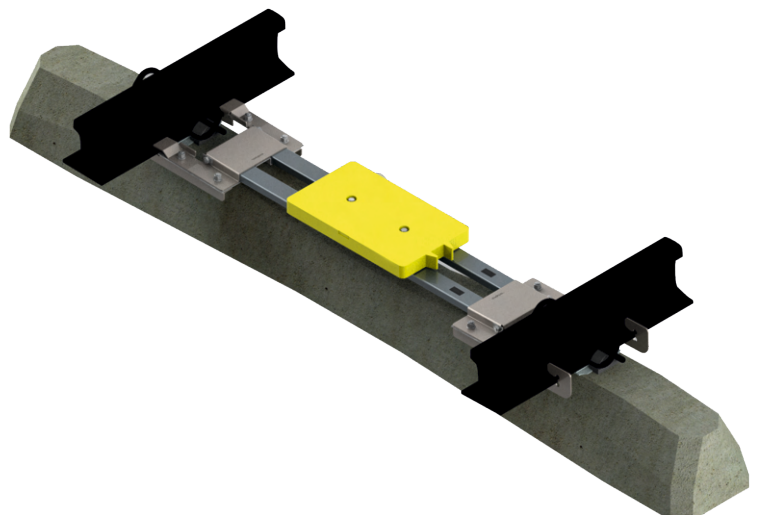

## Key Features:

### **Universal Fastening for Different Rail Types and Fastenings:**

The MBK balise mounting system offers a universal fastening solution that is compatible with various rail types (60, 54, 49, R65) and different rail fastening systems (SB, SKL, others). This ensures adaptability across diverse rail configurations.

### **Drill-Free Installation:**

The system allows for balise installation without the need for drilling holes, simplifying and speeding up the installation process while minimizing disruption to the track structure.

### **No Interference with Sleepers and Rail Fastenings:**

Balise installation can be achieved without interfering with sleepers and existing rail fastenings, preserving the integrity of the track infrastructure.

### **Maintenance Compatibility:**

The design permits sleeper and turnout maintenance without interfering with the balise fastening, enabling efficient maintenance operations.

### **Rail Position Compensation:**

The system compensates for rail movement and vibration during train operation, ensuring the balise remains accurately positioned over time.

### **Resistance to Environmental Conditions:**

The MBK balise system is engineered to withstand long-term environmental factors, including UV radiation, ensuring durability and reliability in various conditions.

### **Electrical Insulation:**

It provides effective electrical insulation between rails and the balise, meeting safety and operational standards.

### **Rail Vibration Damping:**

The system is designed to dampen rail vibrations transferred to the balise, maintaining stability and performance.

### **Material Options:**

Rail handlers are available in stainless steel or construction steel, providing flexibility to meet specific operational needs.

## Compliance with Standards:

The fastening system meets the requirements defined in FFFIS for Eurobalise ERTMS/ETCS-Class 1, approved by leading railway industry players including ALSTOM, ANSALDO, AZD, CAF, SIEMENS, and HITACHI.

## Testing:

The positive ice shot test conducted at the DRL Institute in Stuttgart validates its performance under challenging conditions.

## Advantages for Users:

### Ease of Installation:

The MBK mounting system simplifies the process of installing balises, reducing installation time and labor costs.

### Compatibility and Interference-Free Design:

Users can integrate balises into existing railway infrastructure without compromising the integrity of rail fastening systems.

### Secure Mounting:

MBK-1 mounting type ensures that balises are securely fastened to the railway track, minimizing the risk of displacement or damage during train operations.

# 5.1

## MBK PROTECTOR

The Kolster balise fastening system MBK-1, can be enhanced with a protective cover designed to safeguard the balise from various forms of damage, such as impacts from foreign objects (e.g., ice blocks, stones) and potential vandalism.

### Design and Characteristics

**Material:** The protector is crafted from vulcanized rubber, forming a single, uniform body.

**Durability:** It boasts a robust and stable construction, resistant to UV radiation and aging.

**Weight:** Approximately 17 kg.

**Dimensions:** L x W x H of 680 x 594 x 134 mm.

**Temperature Range:** Operational between -40°C to +70°C, with tolerance to humidity up to 100%.

**Compliance:** Balises equipped with this protector meet the requirements of SUBSET-036 v310.

**Non-interference:** The cover does not impede the functionality of the balise in any manner.

**Longevity:** Expected lifespan of over 10 years due to the use of durable vulcanized rubber.

**Simple Operation:** The protector features a straightforward design and usage, requiring no lubrication or maintenance.

**Alignment Aid:** Horizontal lines marked (0-10-20-30-40-50) on the protector's side planes aid in the accurate positioning of the balise when coupled with the SPBK-1 balise position check tool by Kolster.

### Usage and Compatibility:

**Specific Compatibility:** This protector is solely compatible with the Kolster balise fastening system MBK-1.

**Caution:** Kolster advises against using this protector with other balise fixing systems from different manufacturers, as it may not fit properly or could lead to improper functionality.



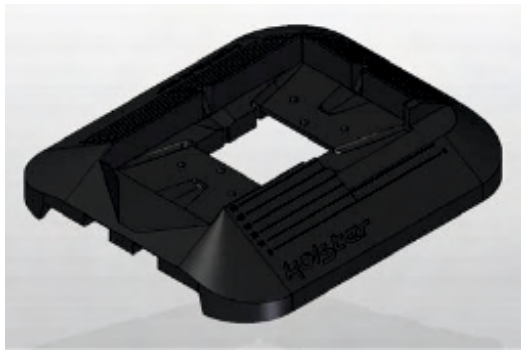

a) 04-67014/2

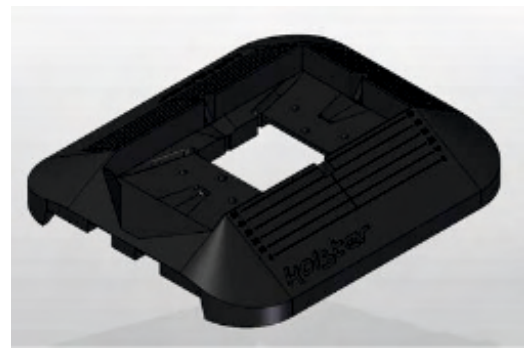

b) 04-67014/1

View of the protector in two versions: a) for Alstom switchable balise, b) for other balises.

Variants of the MBK-1 balise mounting system

		MBK							
Type of steel used for mounting	Steel parts made of hot dip galvanised steel in accordance with standard (durability of the coating in accordance with PN-EN ISO 1461 and PN-EN ISO 14713)	1							
	Steel parts made of Magnelis ZM310 coated steel (durability of coating according to Arcellor Mittal declaration)	1MS							
	Steel parts made of AISI 304L3 steel (corrosion resistance according to manufacturer's declaration)	1SS							
Mounting the balise	Four bolts with 270x120 mm spacing as used in CBC2010, CBF2010, DTR0000304078A, TRVP061381000 and other balises with this mounting geometry.		BC						
	Two bolts with 200 mm spacing, as used in S21, S22 balises and others with this mounting geometry.		BS						
Type of Surface	Installation between or above the sleepers INBK-4, INBK-7, INBK-8, PS-83, PS-93, PS-94			-					
	Monolithic concrete surface			NM					
	NM Steel sleepers type Y			Y					
Permissible speed	Lesser equal to 200 km/h					-			
	Lesser equal to 300 km/h (execution with protector 04-67014/1)					P1			
	Lesser equal to 300 km/h (execution with protector 04-67014/2)					P2			
Direction of balise installation	Installing the longer side of the balise perpendicular to the longitudinal axis of the track							-	
	Longer side of the balise installed parallel to the longitudinal axis of the track							R	

#### Coding example of the MBK-1 system in different application:

**1.** Made of galvanized steel for an Alstom balise, installed in the track above the INBK- 4 or INBK-7 or INBK-8 or PS-83 or PS-93 or PS-94 sleeper with a permitted running speed of up to 300 km/h and fixing the balise with the longer side perpendicular to the longitudinal axis of the track: MBK-1\_BC\_P.

**2.** Made of AISI 304L steel for the Bombardier balise, installed in a track with monolithic concrete track surface with a maximum speed of 300 km/h and the longer side of the balise mounted parallel to the longitudinal axis of the track: MBK-1SS\_BC\_NM\_P\_R.

**3.** Made of Magnelis-coated steel for Bombardier balises, installed in track with sleepers INBK-4 or INBK-7 or INBK-8 or PS-83 or PS-93 or PS-94, and with the longer side of the balise parallel to the longitudinal axis of the track: MBK-1MS\_BS\_P\_R.



# 6

## BACKDRIVES

---

## 6

## BACKDRIVES / DOUBLE-ROD COUPLING MECHANISMS

Mechanical backdrives with single point machine are an alternative, cost-effective solution compared to multi-drive systems. Kolster Sp. z o.o. currently manufactures double-rod mechanical coupling mechanisms designed for switches and swing nose crossing. The double-rod backdrive provides better force transmission from the point machine to the switch interlocking devices than single-rod solution because the connecting rods work exclusively in tension.

### Application

SPZ double-rod coupling mechanisms can be used for standard and curved turnouts with wooden or concrete sleepers, with or without protective covers for the interlockings, as well as with steel switch sleepers used on the PKP network. The SPZ-60 backdrives are used for both switch interlocking and movable frog locks. They are produced for turnouts with radii of 500, 760, and 1200 meters, in versions for installation on either the opposite side of the track from the point machine or on the same side as the drive. Where possible, it is recommended to use backdrive installed on the opposite side.

Mechanical couplings of interlocking devices SPZ-60 are designed for application at speeds  $V_{max} \leq 200$  km/h, for turnouts on P200 and M200 lines, as well as for turnouts on other types of lines specified in PKP PLK Technical Standards.

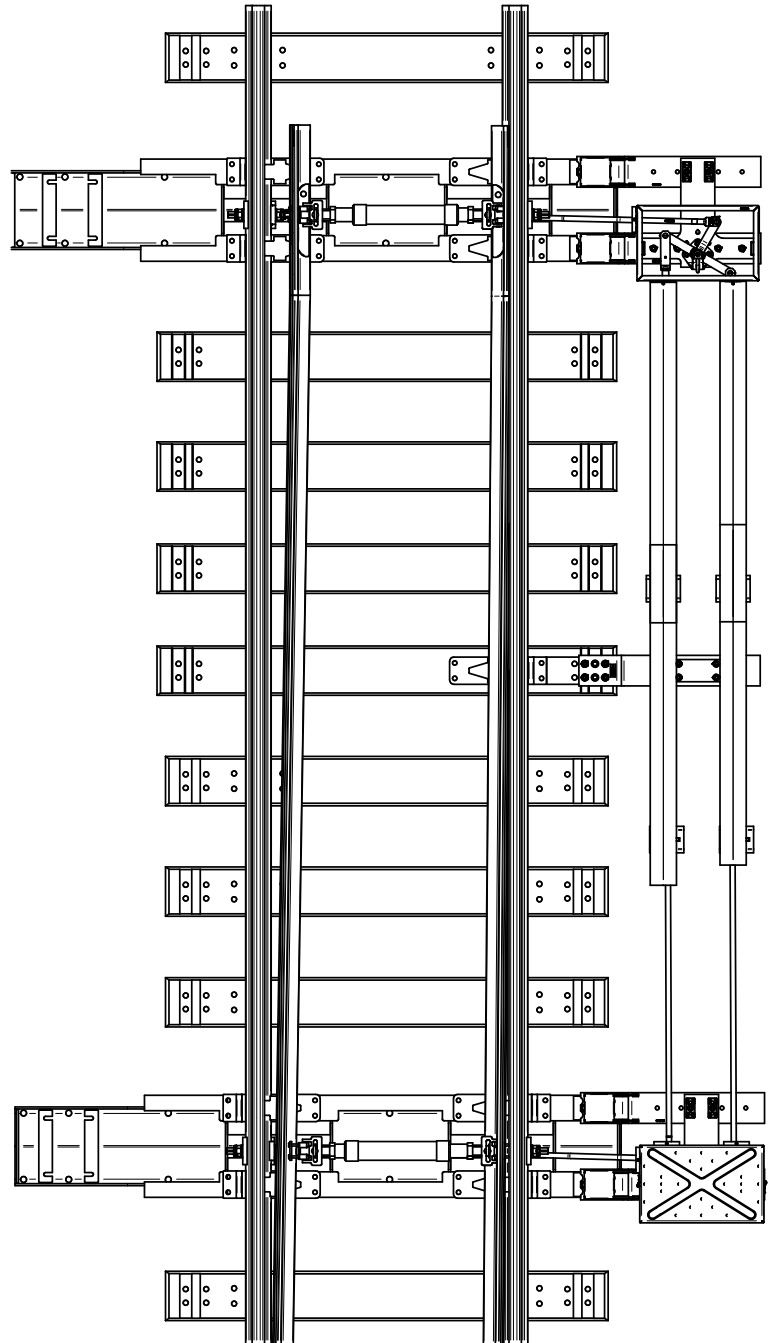

Fig. 1 Backdrive by the turnout with three interlocking devices

For more information on product type and selection, please contact us directly.

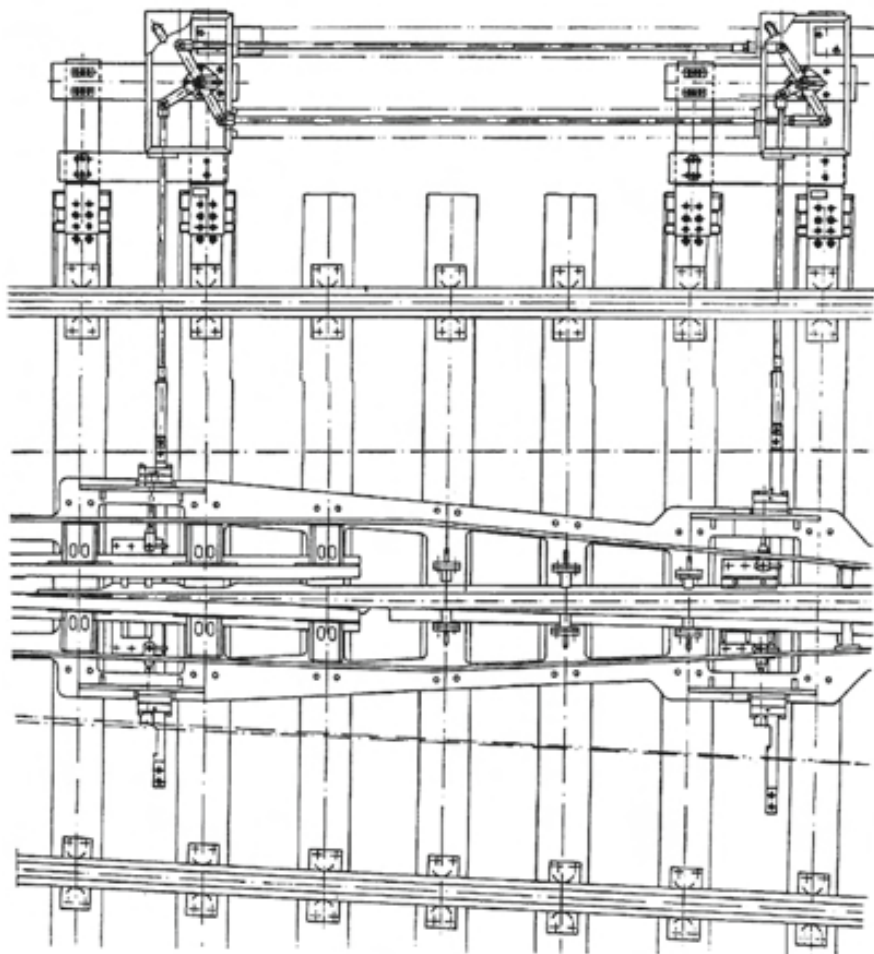
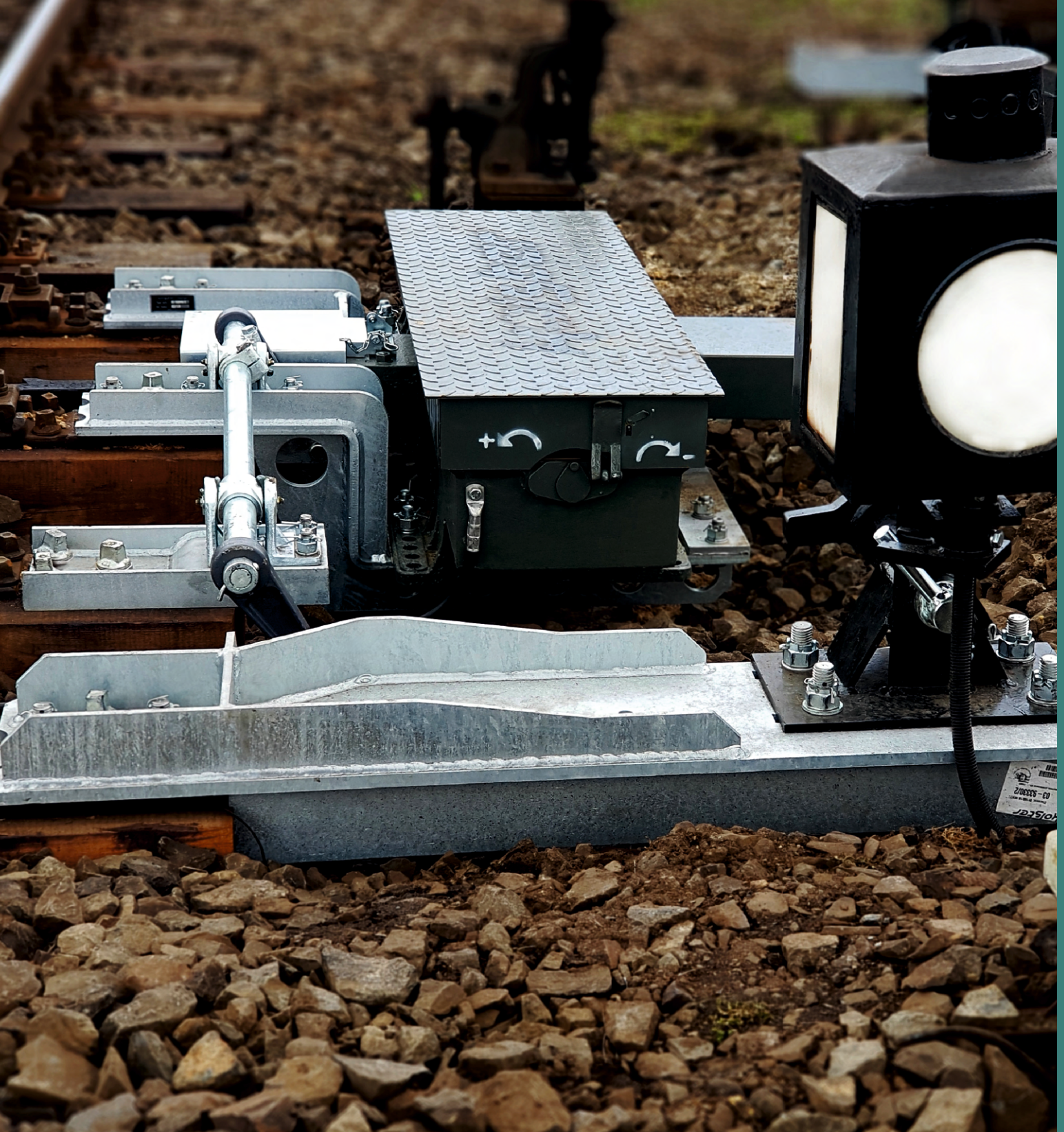

Fig. 2 Backdrive by the swing nose crossing



# 7

MOUNTING KITS FOR POINT MACHINE

---

## 7

## MOUNTING KITS FOR POINT MACHINE

The fixing kits for point machines are used for mounting and connecting with derailleurs or any type of turnouts S42, S49 (49E1), or UIC 60 (60E1) equipped with point machines on wooden sleepers, prestressed concrete sleepers, steel switch sleepers or with switch locking covers. The mounting kits for point machines consist of a mounting and a throwing rod, and for turnouts with point blade control, also detection rods. Our current offer includes fixtures for turnout drives manufactured by Kolster, Alstom, AŽD, Siemens, VAE, and Hitachi on Polish rail infrastructure. Fixing kits are suitable for point machines in trailable and non-trailable version.

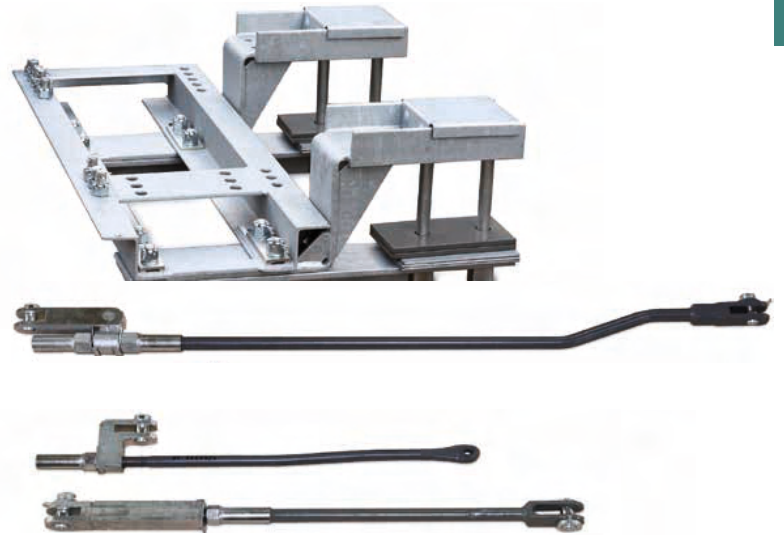

Fig. 1 Fixing kit for Bombardier/Alstom point machine

The mountings and rods are produced only in insulated versions. The length of the rods can be smoothly adjusted within a specified range.

Our company has implemented a large number of rod end forgings, allowing for cost optimization in manufacturing. The production technology of the mountings is available in both welded versions and versions utilizing stamping processes, depending on the client's requirements and needs.

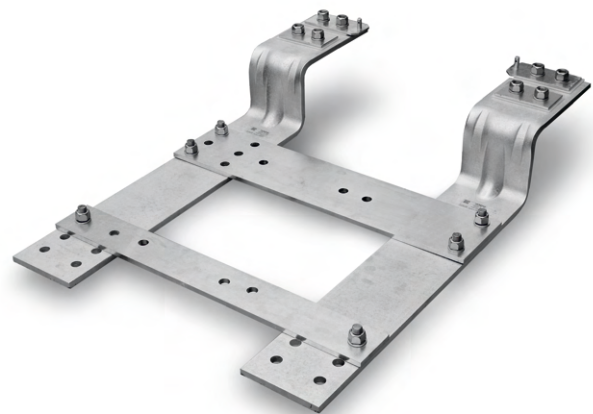
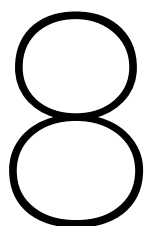

Fig. 2 Fixing kit for SK700S

**For more information on product type and selection, please contact us directly.**



## CABLE ACCESSORIES

---

# 8.1 VF-10 AND JVF-10 JUNCTION POTS

VF-10 and JVF-10 junction pots are designed for the distribution of main cable wires and their connection to outgoing cable wires. Each outgoing cable is provided with a separate terminal block with 7 terminals. The chamber of the junction pot, where the terminal blocks are installed, is sealed. The housing and base of the junction pot are made of cast iron, ensuring high durability and resistance to harmful factors. VF-10 and JVF-10 junction pots are ideal for use in environments where robust and reliable cable connections are required.



Fig. 1 VF-10 Junction Pots



Fig. 2 JVF-10 Junction Pots

## Key Features:

### Housing and Base:

Constructed from cast iron, providing significant durability and resistance to environmental damage.

### Sealed Chamber:

The chamber containing the terminal strips is sealed to protect against dust, moisture, and other contaminants.

### Separate Block for Each Cable:

Each outgoing cable is connected via a , spring terminal block, each with 7 terminals. The same type of terminal block is used across all versions of the junction pots.

### Versions:

The junction pots are available in several versions, differing in the number of terminals and the number of cable outputs.

Table 1 Variants of VF-10 and JVF-10 Junction Pots

Item no.	Number of cable entries	Number of terminals
VF-1010/1B	2	14
VF-1010/1AB	2	14
VF-1011/1B	3	21
VF-1011/1AB	3	21
JVF1001/1B	4	28
JVF-1001/1AB	4	25
JVF-1002B	8	56
JVF-1003B	10	70

Junction pots can be equipped with an anti-theft cover made of plastic. These are designated with an "A" in their model number (e.g., VF-1010/1A, JVF-1010/1A).

### Placement of the terminal blocks

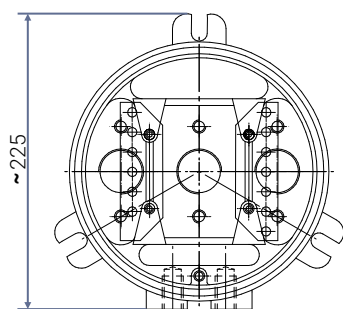

Fig. 3. VF-1010/1 and VF-1010/1A

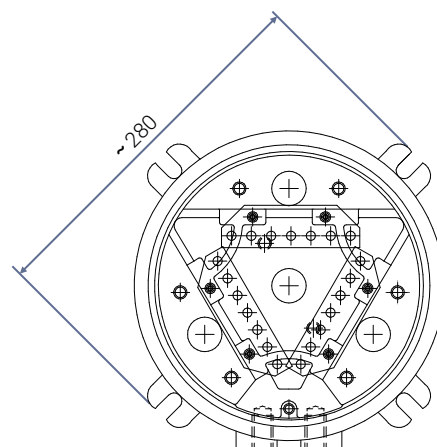

Fig. 4 VF-1011/1 and VF-1011/1A

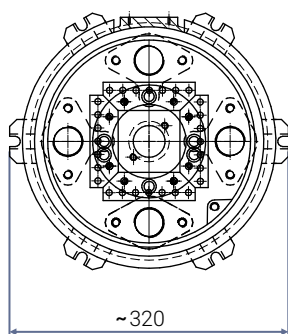

Fig. 5 VF-1001/1 and VF-1001/1A

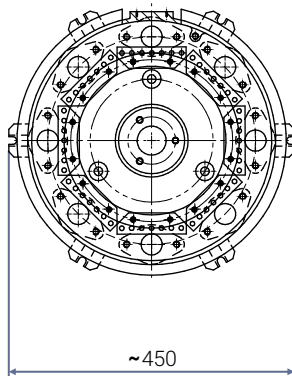

Fig. 6. VF-1002

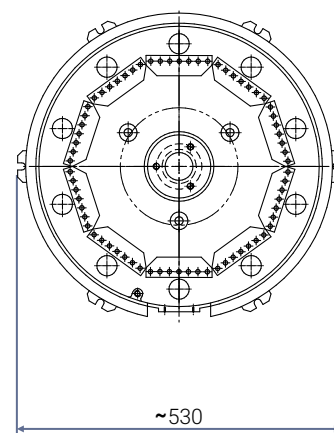

Fig. 7 VF-1003

# 8.2

## JVA -10 TERMINAL BOX

JVA-10 terminal boxes are designed for connecting cables to switch drive units, light signals, indicators, street signal lights, and other devices. They are intended for operation at voltages up to 500V.

### Key Features:

#### Direct Connection:

The boxes can be directly connected to devices using screws.

#### Indirect Connection:

Alternatively, they can be installed separately on VW-10 brackets and connected with flexible protective metal conduits, which is beneficial if the electrical apparatus is exposed to strong vibrations or shifts.

VW-10 brackets are not part of the standard equipment and are provided upon the customer's request.

#### Housing and Covers:

Made of cast iron, ensuring high durability and resistance to harmful environmental factors.

#### Anti-theft Versions:

Feature plastic covers.

#### Terminal Blocks:

Mounted on a DIN rail are high-quality pass-through terminal blocks feature spring clamps, significantly facilitating the installation of wires while ensuring a secure connection.

#### Cable Entries:

Located at the bottom of the box.

### Sealing and Protection:

#### Gasket

Placed in the cover, providing protection against moisture and contaminants.

#### Coating:

The boxes are protected with black paint.

#### Coating:

JVA-10 boxes are produced in several versions differing in the number of cable entries and the number of terminals.

JVA-10 boxes are produced in several versions differing in the number of cable entries and the number of terminals.

Table 2 Variants of JVA-10 terminal boxes

Item no.	Number of terminals	Number of cable entries	Cable flange	Flexible protective metal/ rubber conduits	Others
JVA-1001B JVA-1001AB	12	1	normal	04-63002/1	
JVA-1001/1B JVA-1001/1AB	12	1	normal	04-63002/1	G4-92090 (metal conduits)
JVA-1001/2B JVA-1001/2AB	12	1	extended	04-63002/2	
JVA-1001/21B JVA-1001/21AB	12	1	extended	04-63002/2	screws M10x40
JVA-1001/22B JVA-1001/22AB	12	1	extended	04-63002/2	
JVA-1001/23B JVA-1001/23AB	12	1	extended	04-63002/2	
JVA-1001/24B JVA-1001/24AB	12	1	extended	04-63002/2	4-67245 (rubber hose) pipe 3-26001
JVA-1001/25B JVA-1001/25AB	12	1	extended	04-63002/2	metal cable 4-93134
JVA-1001/27B JVA-1001/27AB	12	1	extended	04-63002/2	4-67245 (rubber hose) pipe 3-26001
JVA-1003B JVA-1003AB	21	2	normal	04-63002/1	
JVA-1003/1B JVA-1003/1AB	21	2	normal	04-63002/1	G4-92090 (metal conduits)
JVA-1003/2B JVA-1003/2AB	21	2	extended	04-63002/2	
JVA-1003/21B JVA-1003/21AB	21	2	extended	04-63002/2	
JVA-1003/22B JVA-1003/22AB	21	2	extended	04-63002/2	
JVA-1003/23B JVA-1003/23AB	21	2	extended	04-63002/2	
JVA-1003/24B JVA-1003/24AB	21	2	extended	04-63002/2	4-68245 (rubber hose)
JVA-1003/25B JVA-1003/25AB	21	2	extended	04-63002/2	4-93134 (metal conduits)
JVA-1005B JVA-1005AB	33	3	normal	04-63002/1	
JVA-1005/1B JVA-1005/1AB	33	3	normal	04-63002/1	G4-92090 (metal conduits)
JVA-1005/2B JVA-1005/2AB	33	3	extended	04-63002/2	
JVA-1005/21B JVA-1005/21AB	33	3	extended	04-63002/2	screws M10x40
JVA-1005/22B JVA-1005/22AB	33	3	extended	04-63002/2	
JVA-1005/23B JVA-1005/23AB	33	3	extended	04-63002/2	
JVA-1005/24B JVA-1005/24AB	33	3	extended	04-63002/2	pipe 3-26001
JVA-1005/25B JVA-1005/25AB	33	3	extended	04-63002/2	4-93134 (metal conduits)

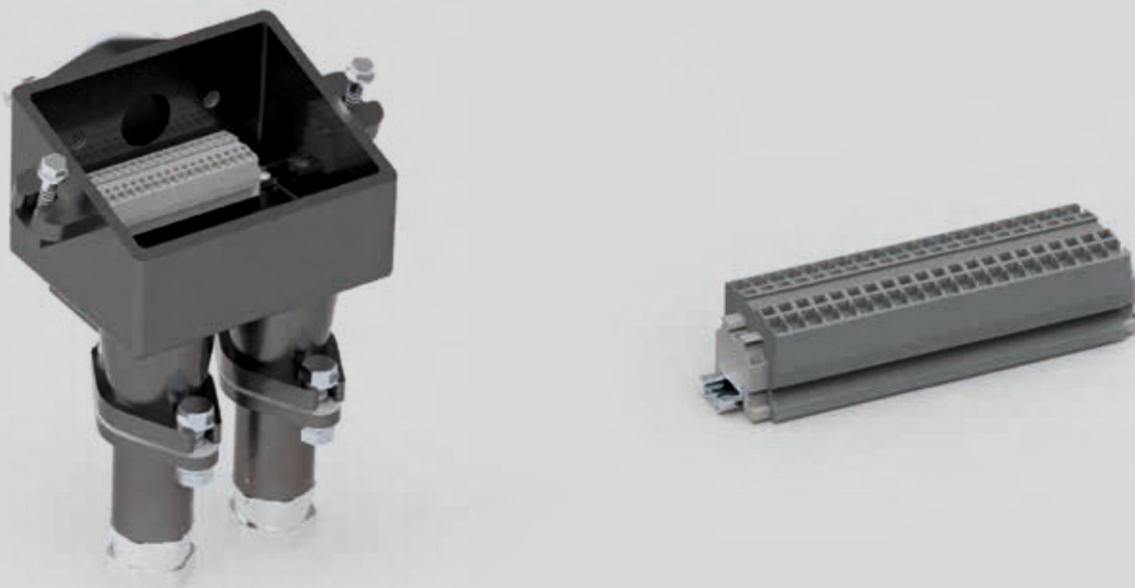

Fig. 8 Terminal box JVA-1003 and terminal block

Kolster offers JVA-20 terminal boxes, specifically designed for connecting cables to insulated track circuits or other trackside equipment. These boxes can handle a working voltage of up to 500 V and are installed in the ground using a bracket for secure placement. We will provide more information on this product range upon request.

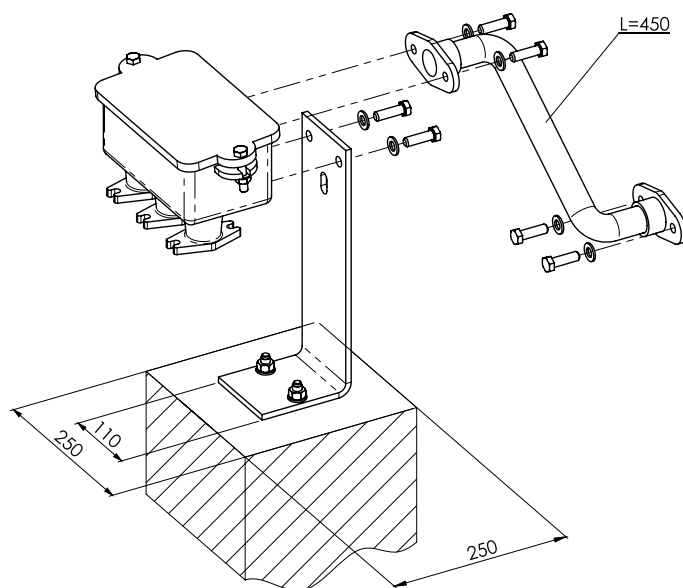

Fig. 9 Indirect Connection of JVA-1003

# 8.3

## MOUNTINGS FOR TERMINAL BOXES AND CABLE ACCESSORIES



Fig. 10 04-63003/1



Fig. 11 04-63002/3



Fig. 12 G4-92090



Fig. 13 4-93134



Fig. 14 4-920210

Table 3 Mounting equipment

Item no.	Description
04-63003/1	Cable flange length 60mm
04-63002/3	Cable flange extended length 150 mm
G4-92090	Flexible protective metal conduits length 450mm
4-93134	Flexible protective metal conduits length 450mm
4-92010	Protective metal-rubber conduits
4-68245	Rubber hose
VW-1001	Bracket with cover
VW-1002	Bracket
04-30009	Bracket
05-93025/1	Terminal block
05-93025/2	Terminal block
05-93025/3	Terminal block
05-93025/4	Terminal block complete



Fig. 15 VW-1001



Fig. 16 VW-1002



Fig. 17 04-30009

Table 4 Cable accessories

Item no.	Description
05-93025/1	Terminal block
05-93025/2	Terminal block
05-93025/3	Terminal block
05-93025/4	Terminal block complete

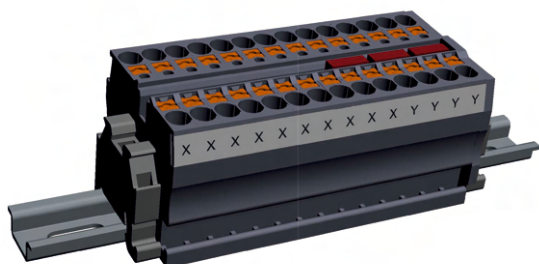

Fig. 18 05-93025/1

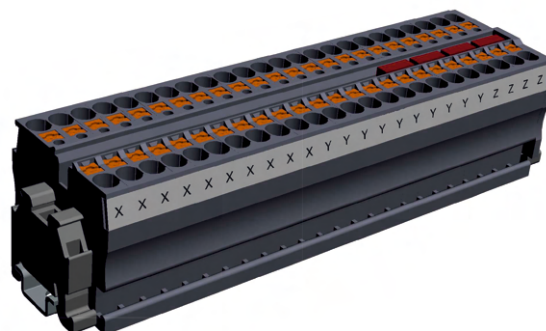

Fig. 19 05-93025/2

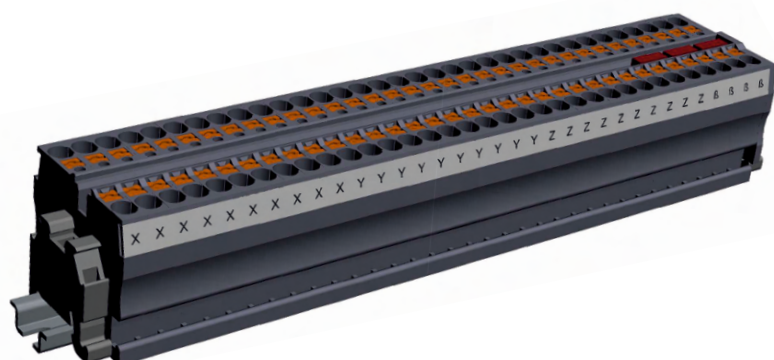

Fig. 20 05-93025/3

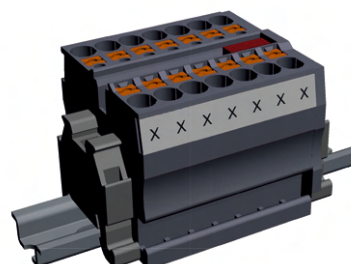

Fig. 21 05-93025/4

# *Kolster*

Kolster Sp. z o.o.  
Lubelska 3  
10-404 Olsztyn, Polen  
T: +48 89 533 02 01  
[info@kolster.com.pl](mailto:info@kolster.com.pl)